



A Professional Manufacturer of Display

Manufacturer Certificated



CERT. No.: 282Q19070712006



CERT. No.: 282E19070712007

Product Specification

Model: TTS116BHT-04

11.6" TFT Display Module(1920*1080)

This module uses RoHS material

Tailor Pixels Technology Co., Ltd.

www.tailorpixels.com

tailor@tailorpixels.com

Ph: 86-755-8821 2653

REVISION HISTORY

() preliminary specification

(√) Final specification

REV.	Page	DESCRIPTION OF CHANGES	DATE	PREPARED
P0	-	Initial Release	2021.8.17	Laughing

Contents

No.	Items	Page
1.0	General Description	4
2.0	Absolute Maximum ratings	6
3.0	Electrical specifications.	7
4.0	Optical specifications.	9
5.0	Interface Connection	13
6.0	Signal Timing Specifications	17
7.0	INPUT SIGNALS, BASIC DISPLAY COLORS & GRAY SCALE OF COLORS	18
8.0	POWER SEQUENCE	19
9.0	MECHANICAL CHARACTERISTICS	20
10.0	RELIABILITY TEST	21
11.0	PRECAUTIONS	22
12.0	Mechanical Outline Dimension	27

1.0 GENERAL DESCRIPTION

1.0.1 Introduction

TTS116BHT-04 is a color active matrix TFT LCD FOB using amorphous silicon TFT's (Thin Film Transistors) as an active switching devices. This FOB has a 11.60 inch diagonally measured active area with FHD resolutions (1920 horizontal by 1080 vertical pixel array). Each pixel is divided into RED, GREEN, BLUE dots which are arranged in vertical stripe and this module can display 16.7M colors. The TFT-LCD panel used for this module is adapted for a low reflection and higher color type.

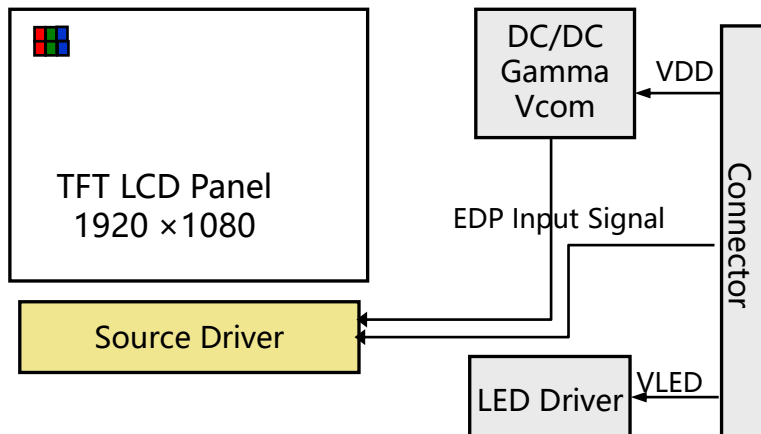

1.0.2 Features

- EDP interface
- RoHS Compliant

1.0.3 Application

- HMI (Human Machine Interface)

1.0.4 General Specification

< Table 1. General Specifications >

Parameter	Specification	Unit	Remarks
Active area	256.320 (H) × 144.180(V)	mm	
Number of pixels	1920(H) × 1080(V)	Pixels	
Pixel pitch	0.1335(H) × 0.1335 (V)	mm	
Pixel arrangement	RGB Vertical stripe		
Display colors	16.7M	Colors	8bit
Display mode	Normally Black		
Dimensional outline	263.4 (H) X 157.82 (V) X 4.5(MAX)	mm	
Brightness	300 min	cd/m2	

2.0 ABSOLUTE MAXIMUM RATINGS

The followings are maximum values which, if exceed, may cause faulty operation or damage to the unit. The operational and non-operational maximum voltage and current values are listed in Table 2.

< Table 2. LCD FOB Electrical Specifications > [Ta =25±2 °C]

Parameter	Symbol	Min.	Max.	Unit	Remarks
LCD Power Supply Voltage	VDD	-0.3	3.6	V	
Back-light Power Supply Voltage	HV _{DDOUT}	2.7	24	V	
Back-light Power Supply Current	I _{ledout}	6	25	mA	typ10.7
Back-light LED Reverse Voltage	V _R	-	-	V	
Operating Temperature	T _{OP}	-10	50	°C	
Storage Temperature	T _{ST}	-20	60	°C	

3.0 ELECTRICAL SPECIFICATIONS

3.0.1 TFT LCD FOB

< Table 3. LCD FOB Electrical Specifications >

[Ta =25 ± 2 °C]

Parameter	Symbol	Values			Unit	Notes
		Min	Typ	Max		
Power Supply Input Voltage	V_{DD}	3.0	3.3	3.6	V	Note 1
Power Supply Current	I_{DD}	-	-	-	mA	
Positive-going Input Threshold Voltage	V_{IT+}	-		+100	mV	Vcom = 4.6V typ.
Negative-going Input Threshold Voltage	V_{IT-}	-100		-	mV	
Differential input common mode voltage	V_{com}		4.6		V	$V_{IH}=100mV$, $V_{IL}=-100mV$

Notes : 1. The supply voltage is measured and specified at the interface connector of FOB.
 The current draw and power consumption specified is for 3.3V at 25 °C
 Max value at Sub V-line Pattern

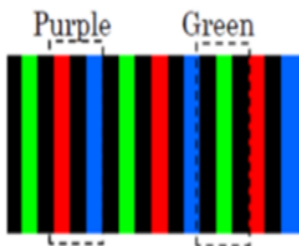

3.0 ELECTRICAL SPECIFICATIONS

3.0.2 TFT LCD FOB

< Table 4. LED Driving guideline specifications >

Parameter		Min.	Typ.	Max.	Unit	Remarks	
Input Supply Voltage		V_{in}	5	12	21	V	
Power supply voltage for Back light		V_{LED}	5	24	37	V	
Power supply Current for Back light		I_{LED}	-	100	-	mA	
Power supply for Back light		P_{LED}	-	2.4	-	W	Note 1
EN Control Level	Backlight on	V_{ENH}	1.2	-	5.0	V	EN logic high voltage
	Backlight off	V_{ENL}	0	-	0.6	V	EN logic low voltage
PWM Control Level	PWM High Level	V_{PML}	1.2	-	5.0	V	
	PWM Low Level	V_{PML}	0	-	0.6	V	
PWM Control Frequency		F_{PWM}	200	-	20000	Hz	
Duty Ratio		-	5	-	100	%	

Notes : 1. Calculator Value for reference $CH \times I_{LED} \times V_{LED} / \text{driver efficiency} = P_{LED}$

2. The LED Life-time define as the estimated time to 50% degradation of initial luminous under the condition of the ambient temperature of 25°C.

4.0 OPTICAL SPECIFICATION

4.0.1 Overview

The test of view angle range shall be measured in a dark room (ambient luminance ≤ 1 lux and temperature = $25 \pm 2^\circ\text{C}$) with the equipment of Luminance meter system (Goniometer system and TOPCON CS2000/CA310) and test unit shall be located at an approximate distance 50cm from the LCD surface at a viewing angle of θ and Φ equal to 0° . We refer to $\theta\emptyset=0$ ($=\theta_3$) as the 3 o'clock direction (the "right"), $\theta\emptyset=90$ ($=\theta_{12}$) as the 12 o'clock direction ("upward"), $\theta\emptyset=180$ ($=\theta_9$) as the 9 o'clock direction ("left") and $\theta\emptyset=270$ ($=\theta_6$) as the 6 o'clock direction ("bottom"). While scanning θ and/or \emptyset , the center of the measuring spot on the Display surface shall stay fixed. The luminance, color and uniformity (etc) should be tested by CS2000/CA310. VDD shall be $3.3 \pm 0.3\text{V}$ at 25°C . Optimum viewing angle direction is 6 'clock

<Table 5. Optical Specifications>

Parameter		Symbol	Condition	Min.	Typ.	Max.	Unit	Remark
Viewing Angle range	Horizontal	Θ_3	CR > 10	-	85	-	Deg.	Note 1
		Θ_9		-	85	-	Deg.	
	Vertical	Θ_{12}		-	85	-	Deg.	
		Θ_6		-	85	-	Deg.	
Luminance Contrast ratio		CR	$\Theta = 0^\circ$	800	1000	-		Note 2
Color Gamut		NTSC	$\Theta = 0^\circ$	67%	72%	-		
Response Time		T_{RT}	$T_a = 25^\circ\text{C}$ $\Theta = 0^\circ$	-	30	35	ms	Note 3
Cross Talk		CT	$\Theta = 0^\circ$	-	-	2.0	%	Note 4
Cell Transmittance		Tr			4		%	

- Notes : 1. Viewing angle is the angle at which the contrast ratio is greater than 10. The viewing angles are determined for the horizontal or 3, 9 o'clock direction and the vertical or 6, 12 o'clock direction with respect to the optical axis which is normal to the LCD surface (see FIGURE 1).
2. Contrast measurements shall be made at viewing angle of $\Theta = 0$ and at the center of the LCD surface. Luminance shall be measured with all pixels in the view field set first to white, then to the dark (black) state. (see FIGURE 1) Luminance Contrast Ratio (CR) is defined mathematically.

$$CR = \frac{\text{Luminance when displaying a white raster}}{\text{Luminance when displaying a black raster}}$$

3. The electro-optical response time measurements shall be made as FIGURE 3 by switching the "data" input signal ON and OFF. The times needed for the luminance to change from 10% to 90% is T_r , and 90% to 10% is T_d .
4. Cross-Talk of one area of the LCD surface by another shall be measured by comparing the luminance (Y_A) of a 25mm diameter area, with all display pixels set to a gray level, to the luminance (Y_B) of that same area when any adjacent area is driven dark. (See FIGURE 4).

4.0.2 Optical measurements

Figure 1. Measurement Set Up

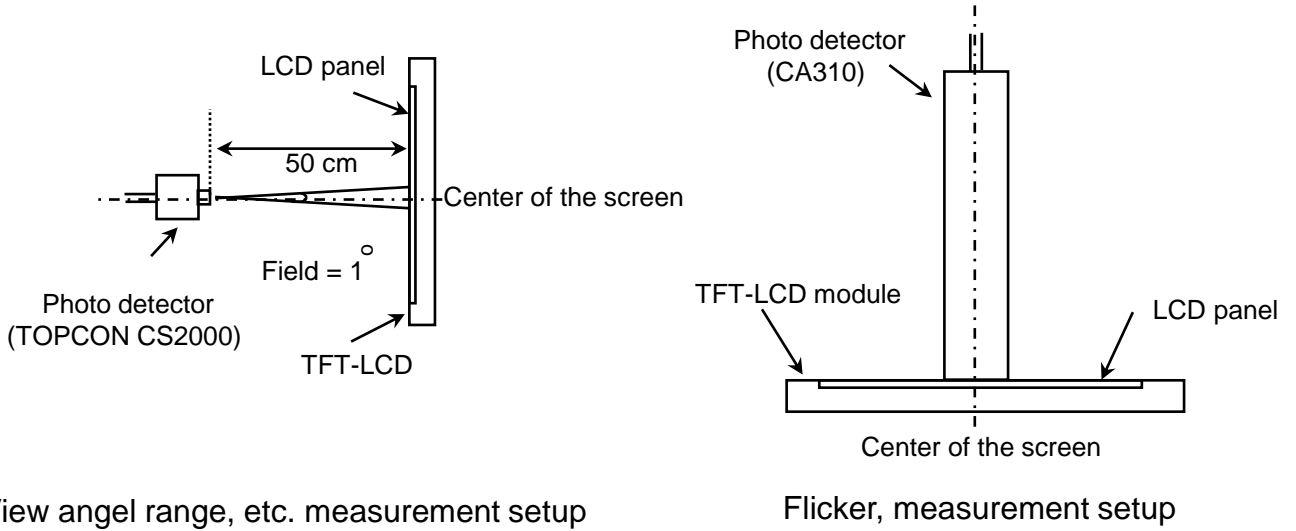

View angle range, etc. measurement setup

Flicker, measurement setup

Figure 2. Response Time Testing

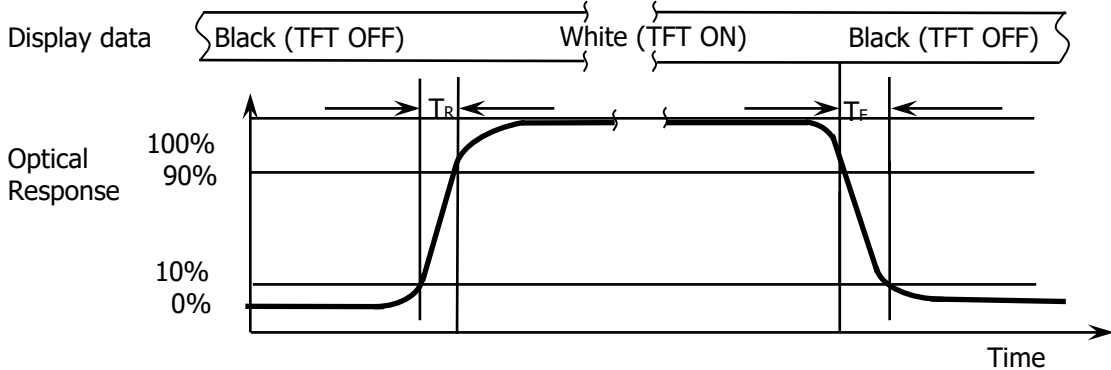

The electro-optical response time measurements shall be made as shown in FIGURE 3 by switching the “data” input signal ON and OFF. The times needed for the luminance to change from 10% to 90% is Tr and 90% to 10% is Td.

Figure 3. Cross Modulation Test Description

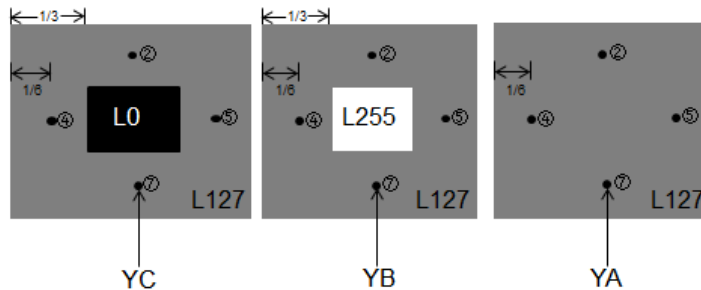

$$\text{White Bar Cross-Talk(\%)} = \left| \frac{YB - YA}{YA} \right| \times 100$$

$$\text{Black Bar Cross-Talk(\%)} = \left| \frac{YC - YA}{YA} \right| \times 100$$

Where:

YA = Initial luminance of measured area (cd/m²)

YB = Subsequent luminance of measured area (cd/m²) @White Bar

YC = Subsequent luminance of measured area (cd/m²) @Black Bar

The location measured will be exactly the same in both patterns

5.0 INTERFACE CONNECTION.

5.0.1 Electrical Interface Connection

The electronics interface connector is S050-L30B-C10(30P)

The connector interface pin assignments are listed in Table 6

<Table 6. Pin Assignments for the Interface Connector>

PIN #	Symbol	Description Remark	PIN #	Symbol	Description Remark
1	CABC-EN	CABC-EN	16	GND	Power Ground
2	GND	Power Ground	17	HPD	Hot plug detect output
3	LANE1-N	eDP RX channel 1 negative	18	BL-GND	Power Ground
4	LANE1-P	eDP RX channel 1 positive	19	BL-GND	Power Ground
5	GND	Power Ground	20	BL-GND	Power Ground
6	LANE0-N	eDP RX channel 0 negative	21	BL-GND	Power Ground
7	LANE0-P	eDP RX channel 0 positive	22	BL-ENABLE	BL-ENABLE
8	GND	Power Ground	23	BL-PWM	Reset low active
9	AUX-CH-P	eDP AUX CH positive	24	MSCL	FOR DEBUG
10	AUX-CH-N	eDP AUX CH negative	25	MSDA	FOR DEBUG
11	GND	Power Ground	26	BL-POWER	BL-POWER
12	LDC-VC C	3.3V	27	BL-POWER	BL-POWER
13	LCD-VC C	3.3V	28	BL-POWER	BL-POWER
14	LCD-TEST	Panel self test enable	29	BL-POWER	BL-POWER
15	GND	Power Ground	30	NC	NC

5.0.2 EDP Interface

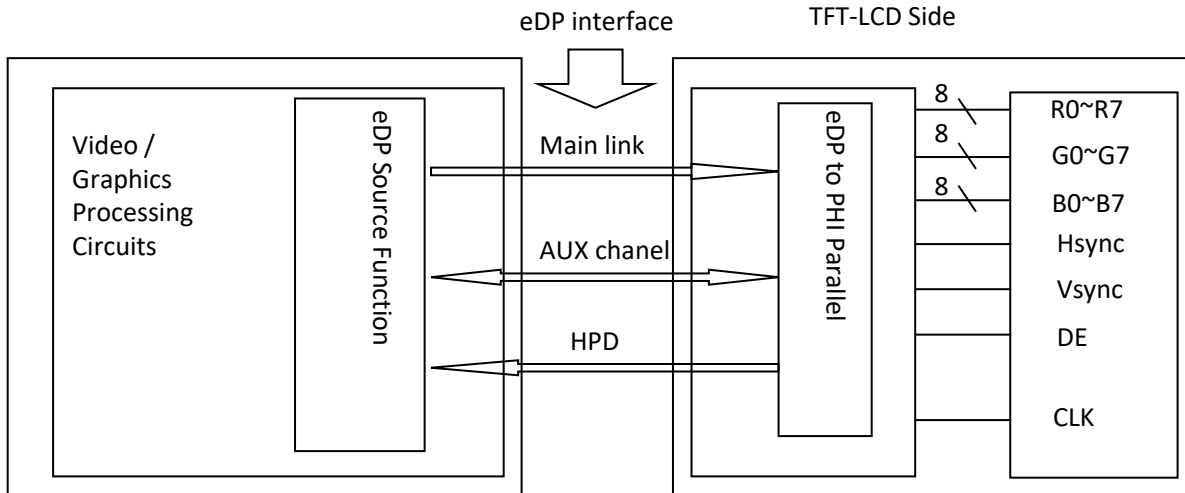

5.0.3 Data Input Format

Figure 5. Pixel Format

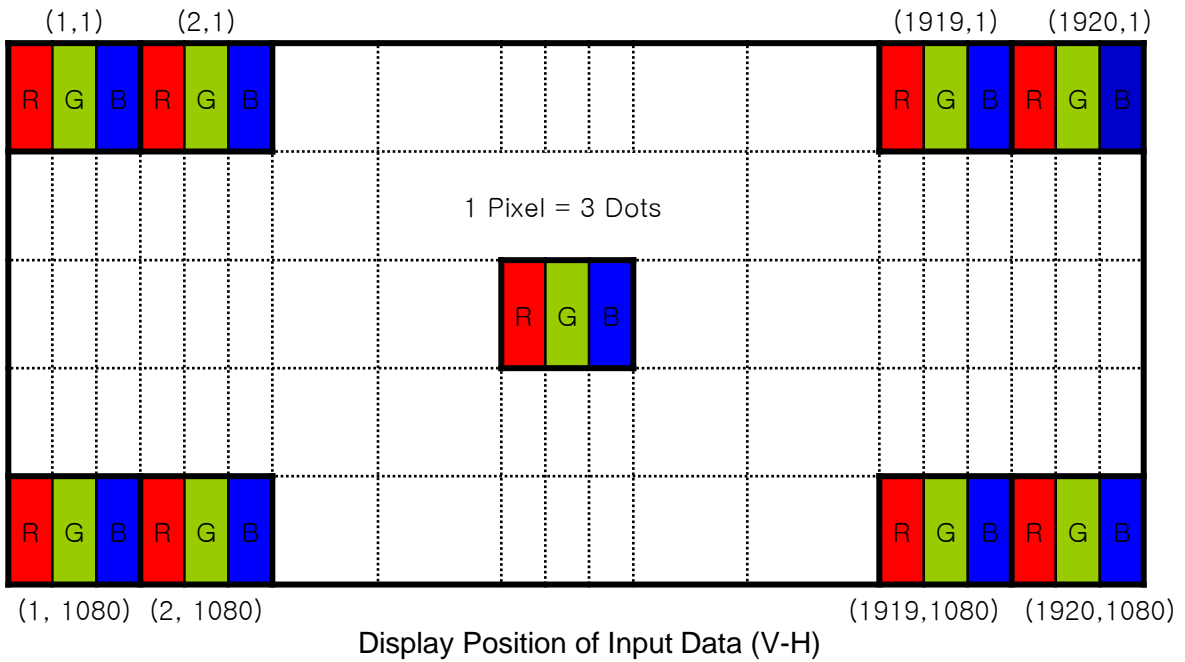
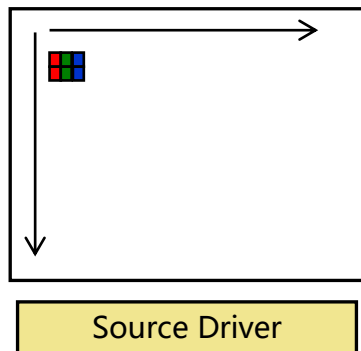

Figure 6. Scan direction



5.0.4 LED CONNECT

PIN #	Symbol	Description Remark
1	LED1	LED-
2	LED2	
3	LED3	
4	LED4	
5	LED5	
6	LED6	
7	NC	NC
8	VLEDOUT	LED+
9	VLEDOUT	
10	VLEDOUT	

6.0 SIGNAL TIMING SPECIFICATION

6.0.1 The M116B40-121-0802 is operated by the DE only.

Parameter	Symbol	Value			Unit
		Min.	Typ.	Max.	
DCLK Frequency	fclk	138.5	148.5	177.1	MHz
Horizontal display area	thd	1920			pixel
HSYNC period time	th	2080	2200	2400	pixel
HSYNC blanking	thb+ thfp	160	280	480	pixel
Vertical display area	Tvd	1080			H
Frequency	fV	40	60	66	Hz
VSYNC period time	Tv	1110	1125	1230	H
VSYNC blanking	Tvb+ Tvfp	30	45	150	H

8.0 POWER SEQUENCE

To prevent a latch-up or DC operation of the LCD module, the power on/off sequence shall be as shown in below

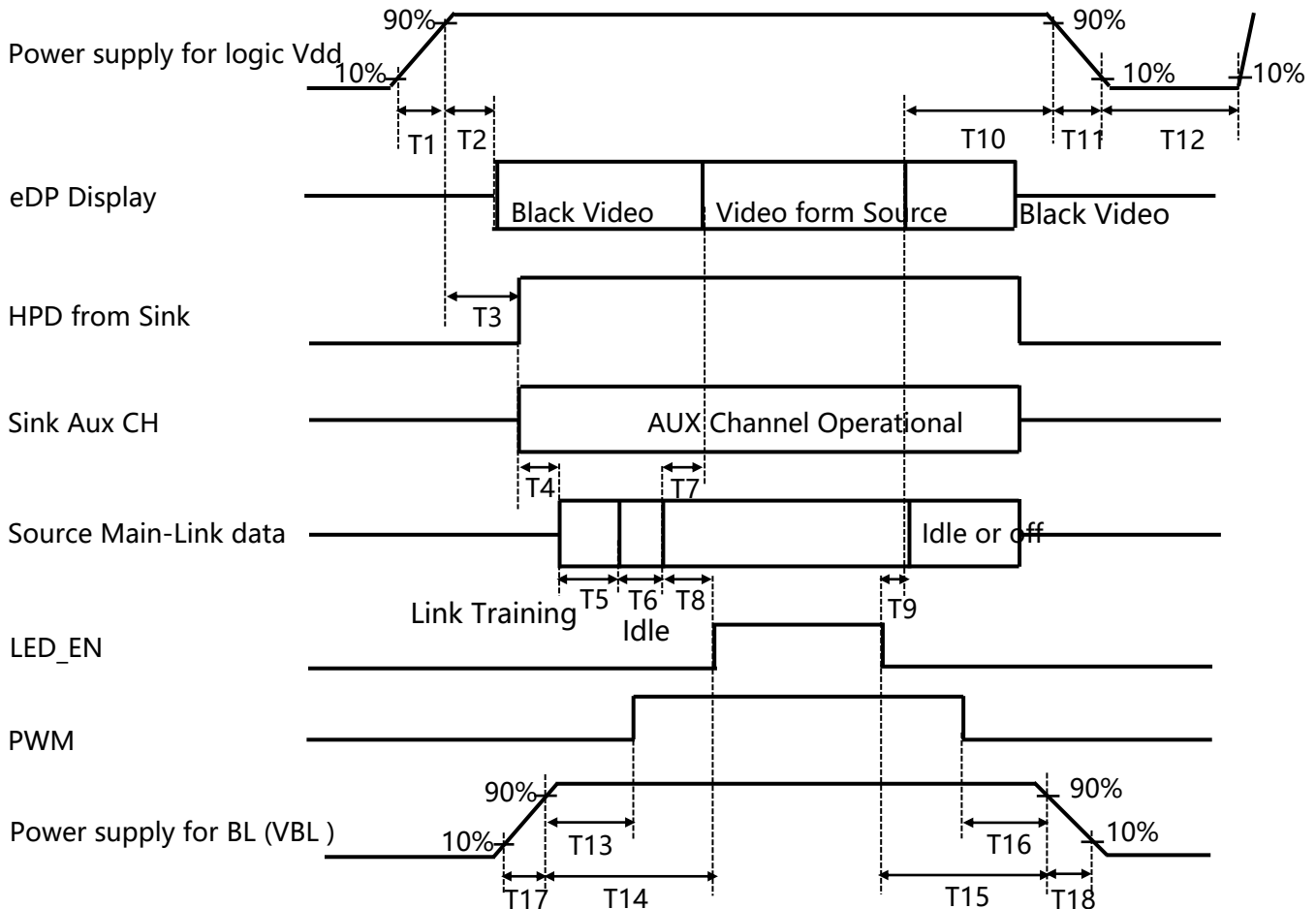

- | | |
|----------------------|-----------------------|
| • 0.5ms ≤ T1 ≤ 10 ms | • 0ms ≤ T7 ≤ 50ms |
| • 0ms ≤ T2 ≤ 200 ms | • 0ms ≤ T10 ≤ 500 ms |
| • 0ms ≤ T3 ≤ 200 ms | • 0.5ms ≤ T11 ≤ 10 ms |
| • 0ms ≤ T13 | • 500ms ≤ T12 |
| • 0ms ≤ T14 | • 0ms ≤ T15 |
| • 0ms ≤ T17 | • 0ms ≤ T16 |
| • 80ms ≤ T8 | • 0ms ≤ T18 |

Notes:

- When the power supply VDD is 0V, keep the level of input signals on the low or keep high impedance.
- Do not keep the interface signal high impedance when power is on. Back Light must be turn on after power for logic and interface signal are valid.

9.0 MECHANICAL CHARACTERISTICS

9.0.1 Dimensional Requirements

<Table 8. Dimensional Parameters>

Parameter	Specification	Unit
Active Area	256.320 (H) × 144.180(V)	mm
Number of pixels	1920(H) X1080 (V) (1 pixel = R + G + B dots)	
Pixel pitch	0.1335(H) × 0.1335 (V)	mm
Pixel arrangement	RGB Vertical stripe	
Display colors	16.7M (8bit)	colors
Display mode	Normally Black	
Dimensional outline	263.4 (H) X 157.82 (V) X 4.5(MAX)	Typ.
Weight	96.6g	Typ.

10.0 RELIABILITY TEST

The Reliability test items and its conditions are shown in below.

<Table 9. Reliability test>

Item		Test condition
High temperature storage		60 °C, 240 hrs
Low temperature storage		-20°C, 240 hrs
High temperature & high humidity operation		50 °C, 90%RH, 240hrs
High temperature operation		50 °C, 240hrs
Low temperature operation		-10°C, 240hrs
Temperature Shock storage		-10~50°C, 1hr/Cycle, 100Cycles
Vibration test	Frequency	10/ 200/10 Hz,Sine X/Y/Z Direction
	Gravity / AMP	1.5 G
	Period	±X, ±Y, ±Z 30 min
Shock test	Gravity	50G
	Pulse width	11msec, Half-sine wave
	Direction	±X, ±Y, ±Z
On/Off test		On/5sec, Off/5sec, 3,000 cycles
ESD	Air	± 15KV, 150pF(330) 1sec, 100 points, 1 times/ point
	Contact	± 8KV, 150pF(330) 1sec, 100 points, 1 times/ point

11.0 PRECAUTIONS

Please pay attention to the followings when you use this TFT LCD Panel.

11.1 Mounting Precautions

- Use finger-stalls with soft gloves in order to keep display clean during the incoming inspection and assembly process.
- You must mount a Panel using specified mounting holes (Details refer to the drawings)
- You should consider the mounting structure so that uneven force (ex. Twisted stress, Concentrated stress) is not applied to the Panel. And the case on which a Panel is mounted should have sufficient strength so that external force is not transmitted directly to the Panel.
- Do not apply mechanical stress or static pressure on Panel; Abnormal display cause by pressing some parts of Panel during assembly process, do not belong to product failure, the press should be agreed by two sides.
- Determine the optimum mounting angle, refer to the viewing angle range in the specification for each model.
- Do not apply mechanical stress or static pressure on Panel, and avoid impact, vibration and falling.
- Acetic acid type and chlorine type materials for the cover case are not desirable because the former generates corrosive gas of attacking the polarizer at high temperature and the latter causes circuit break by electro-chemical reaction.
- Protection film for polarizer on the Panel should be slowly peeled off before display.
- Be careful to prevent water & chemicals contact the Panel surface.
- You should adopt radiation structure to satisfy the temperature specification.
- Do not touch, push or rub the exposed polarizers with glass, tweezers or anything harder than HB pencil lead. And please do not rub with dust clothes with chemical treatment. Do not touch the surface of polarizer for bare hand or greasy cloth.(Some cosmetics are detrimental to the polarizer.)
- When the surface becomes dusty, please wipe gently with absorbent cotton or other soft materials like chamois soaks with petroleum benzine. Normal-hexane & alcohol is recommended for cleaning the adhesives used to attach front / rear polarizers. Do not use acetone, toluene, because they cause chemical damage to the polarizer.
- Wipe off saliva or water drops as soon as possible. Their long time contact with polarizer causes deformations and color fading..

- This Panel has its circuitry PCB's on the rear side and Driver IC, should be handled carefully in order not to be stressed.
- Avoid impose stress on PCB and Driver IC during assembly process ,Do not drawing, bending, COF package & wire
- Do not disassemble the Panel.

11.2 Operating Precautions

- Do not connector or disconnect the cable to/from the Panel at the “Power On” Condition.
- When the Panel is operating, do not lose CLK, ENAB signals. If any one of these signals is lost, the Panel would be damaged.
- Obey the supply voltage sequence. If wrong sequence is applied, the Panel would be damaged.
- Do not allow to adjust the adjustable resistance or switch
- The electrochemical reaction caused by DC voltage will lead to LCD Panel degradation, so DC drive should be avoided.
- The LCD Panels use C-MOS LSI drivers, so customers are recommended that any unused input terminal would be connected to Vdd or Vss, do not input any signals before power is turn on, and ground you body, work/assembly area, assembly equipment to protect against static electricity.
- Do not exceed the absolute maximum rating value. (supply voltage variation, input voltage variation, variation in part contents and environmental temperature, and so on) Otherwise the Panel may be damaged.
- Panel has high frequency circuits. Sufficient suppression to the electromagnetic interference shall be done by system manufacturers. Grounding and shielding methods may be important to minimized the interference.
- Design the length of cable to connect between the connector for back-light and the converter as shorter as possible and the shorter cable shall be connected directly , The long cable between back-light and Converter may cause the Luminance of LED to lower and need a higher startup voltage
- The cables should be as short as possible between System Board and PCB interface.
- Connectors are precision devices to transmit electrical signals, and operators should plug in parallel
- Be careful for condensation at sudden temperature change. Condensation makes damage to polarizer or electrical contacted parts. And after fading condensation, smear or spot will occur.

11.3 Electrostatic Discharge Precautions

- Avoid the use work clothing made of synthetic fibers. We recommend cotton clothing or other conductivity-treated fibers.
- Since a Panel is composed of electronic circuits, it is not strong to electrostatic discharge. Make certain that treatment persons are connected to ground through wrist band etc.
- Do not close to static electricity to avoid product damage.
- Do not touch interface pin directly.

11.4 Precautions for Strong Light Exposure

- Do not leave the Panel operation or storage in Strong light . Strong light exposure causes degradation of polarizer and color filter.

11.5 Precautions for Storage

A. Atmosphere Requirement

ITEM	UNIT	MIN	MAX
Storage Temperature	(°C)	5	40
Storage Humidity	(%rH)	40	75
Storage Life	6 months		
Storage Condition	<ul style="list-style-type: none"> • The storage room should be equipped with a dark and good ventilation facility. • Prevent products from being exposed to the direct sunlight, moisture and water. • The product need to keep away from organic solvent and corrosive gas. • Be careful for condensation at sudden temperature change. • Storage condition is guaranteed under packing conditions. 		

B. Package Requirement

- The product should be placed in a sealed polythene bag.
- Product Should be placed on the pallet, Which is away from the floor, Be cautions not to pile the product up.
- The polarizer surface should not come in contact with any other object. It is recommended that they be stored in the container in which they were shipped.
- As the original protective film, do not use the adhesive protective film to avoid change of Pol color and characteristic.

11.6 Precautions for protection film

- Remove the protective film slowly, keeping the removing direction approximate 30-degree not vertical from panel surface, If possible, under ESD control device like ion blower, and the humidity of working room should be kept over 50%RH to reduce the risk of static charge.
- People who peeled off the protection film should wear anti-static strap and grounded well.

11.7 Appropriate Condition for Display

-Generally large-sized LCD Panels are designed for consumer applications . Accordingly, long-term display application can cause uneven display including image sticking. To optimize Panel's lifetime and function, several operating usages are required.

1. Normal operating condition

- Temperature: $20 \pm 15^{\circ}\text{C}$
- Operating Ambient Humidity : $55 \pm 20\%$
- Display pattern: dynamic pattern (Real display)
- Well-ventilated place is recommended to set up display system

2. Special operating condition

a. Ambient condition

- Well-ventilated place is recommended to set up display system.

b. Power and screen save

- Periodical power-off or screen save is needed after long-term display.

c. As the low temperature, the response time is greatly delayed. As the high temperatures (higher than the operating temperature) the LCD Panel may turn black screen. The above phenomenon cannot explain the failure of the display. When the temperature returns to the normal operating temperature, the LCD Panel will return to normal display.

d. When expose to drastic fluctuation of temperature (hot to cold or cold to hot) ,the LCD Panel may be affected; Specifically, drastic temperature fluctuation from cold to hot ,produces dew on the LCD Panel 's surface which may affect the operation of the polarizer and LCD Panel

e. Do not exceed the absolute maximum rating value. (supply voltage variation, input voltage variation, variation in part contents and environmental temperature, and so on) Otherwise the Panel may be damaged.

f. Product reliability and functions are only guaranteed when the product is used under right operation usages. If product will be used in extreme conditions such as high temperature, high humidity, high altitude, special display images, running time, long time operation, outdoor operation, etc. It is strongly recommended to contact BOE for filed application engineering advice. Otherwise, its reliability and function may not be guaranteed. Extreme conditions are commonly found at airports, transit stations, banks, stock market and controlling systems.

3. Operating usages to protect against image sticking due to long-term static display.

a. Suitable operating time: under 20 hours a day.

b. Static information display recommended to use with moving image.

- Cycling display between 5 minutes' information(static) display and 10 seconds' moving image.

c. Background and character (image) color change

- Use different colors for background and character, respectively.

- Change colors themselves periodically.

d. Avoid combination of background and character with large different luminance.

1) Abnormal condition just means conditions except normal condition.

2) Black image or moving image is strongly recommended as a screen save

11.8 Other Precautions

A. LC Leak

- If the liquid crystal material leaks from the panel, it is recommended to wash the LC with acetone or ethanol and then burn it.
- If the liquid crystal material leaks from the panel, it should be kept away from the eyes or mouth. In case of contact with hands, skin or clothes, it has to be washed away thoroughly with soap.
- If LC in mouth, mouth need to be washed, drink plenty of water to induce vomiting and follow medical advice.
- If LC touch eyes, eyes need to be washed with running water at least 15 minutes.

B. Rework

- When returning the Panel for repair or etc., Please pack the Panel not to be broken. We recommend to use the original shipping packages.

