



A Professional Manufacturer of Display

Manufacturer Certificated



CERT. No.: 282Q19070712006



CERT. No.: 282E19070712007

Product Specification

Model: TTS156BHT-01

15.6" TFT Display Module(1920*1080)

This module uses RoHS material

Tailor Pixels Technology Co., Ltd.

www.tailorpixels.com

tailor@tailorpixels.com

Ph: 86-755-8821 2653

preliminary specification

Final specification

REV.	ECN No.	DESCRIPTION OF CHANGES	DATE	PREPARED
P0		Initial Release	2022-12-05	STH

Contents

No.	Items	Page
1.0	General Description	4
2.0	Absolute Maximum Ratings	6
3.0	Electrical Specifications	7
4.0	INTERFACE CONNECTION	9
5.0	SIGNAL TIMING SPECIFICATION	12
6.0	Optical Specifications	15
7.0	MECHANICAL CHARACTERISTICS	19
8.0	Reliability Test	20
9.0	Packing Information	21
10.0	Handling & Cautions	24
11.0	EDID	30
12.0	Appendix	34

1.0 GENERAL DESCRIPTION

1.1 Introduction

This module is a color active matrix TFT LCD module using amorphous silicon TFT's (Thin Film Transistors) as an active switching devices. This module has a 15.6 inch diagonally measured active area with FHD resolutions (1920 horizontal by 1080 vertical pixel array). Each pixel is divided into RED, GREEN, BLUE dots which are arranged in vertical stripe and this module can display 16.7M colors.

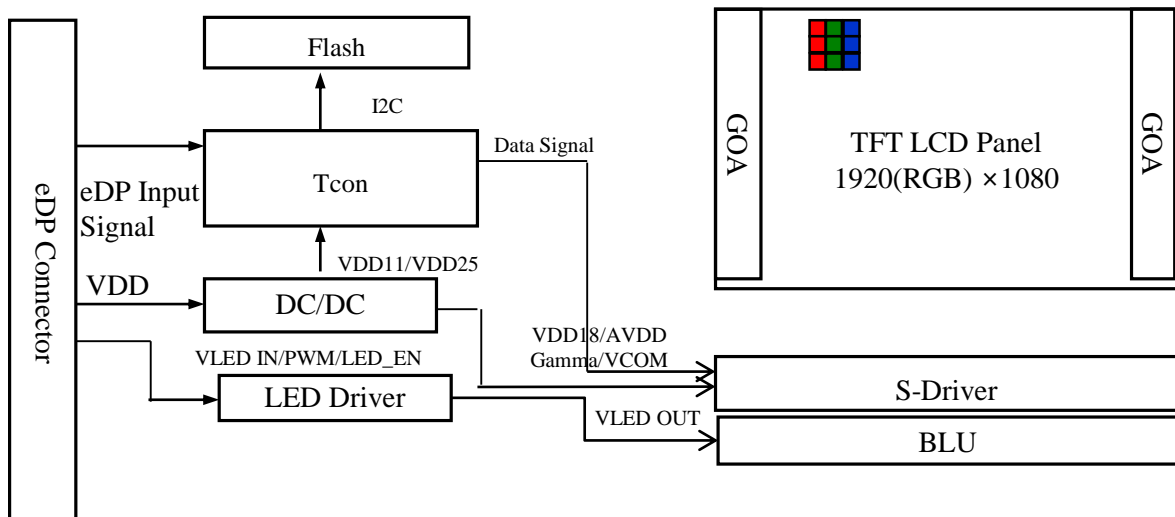

1.2 Features

- 0.4T Glass (Single)
- 6-bit (6bit+FRC) color depth, display 16.7M colors
- eDP 1.4 interface with 2 Lane
- Reverse Type

1.3 Application

- 绘图板

1.4 General Specification

The followings are general specifications

<Table 1. LCD Module Specifications>

Parameter	Specification	Unit	Remarks
Active Area	344.16 (H) × 193.59 (V)	mm	
Number Of Pixels	1920 (H) × 1080 (V)	pixels	
Pixel Pitch	0.17925 (H) X 0.17925 (V)	mm	
Pixel Arrangement	RGB Vertical stripe		
Display Mode	Normally Black		
Display Colors	16.7M	colors	6+FRC
Surface Treatment	Anti Glare		
Viewing Angle(CR>10)	85/85/85/85	deg.	
Response Time	30ms@tpy,35ms@max	ms	
Color Gamut	72%NTSC		
Power Consumption	1.08	watt	
Outline Dimension	350.72*204.98*2.82	mm	

2.0 ABSOLUTE MAXIMUM RATINGS

The followings are maximum values which, if exceed, may cause faulty operation or damage to the unit. The operational and non-operational maximum voltage and current values are listed in Table 2.

< Table 2. Absolute Maximum Ratings >

Parameter	Symbol	Min.	Max.	Unit	Remark
Power Supply Voltage	VDD	-0.3	5.5	V	Ta = 25 °C
Operating Temperature	T _{OP}	0	+50	°C	Note 1
	T _{SUR}	产品表面温度	+65	°C	
Storage Temperature	T _{ST}	-20	+60	°C	
Operating Ambient Humidity	Hop	10	80	%RH	
Storage Humidity	Hst	10	80	%RH	

Note : 1) Temperature and relative humidity range are shown in the figure below.
 Wet bulb temperature should be 39 °C max. and no condensation of water.
 T_{SUR} : Panel surface Temperature is measured at 50°C Dry Condition

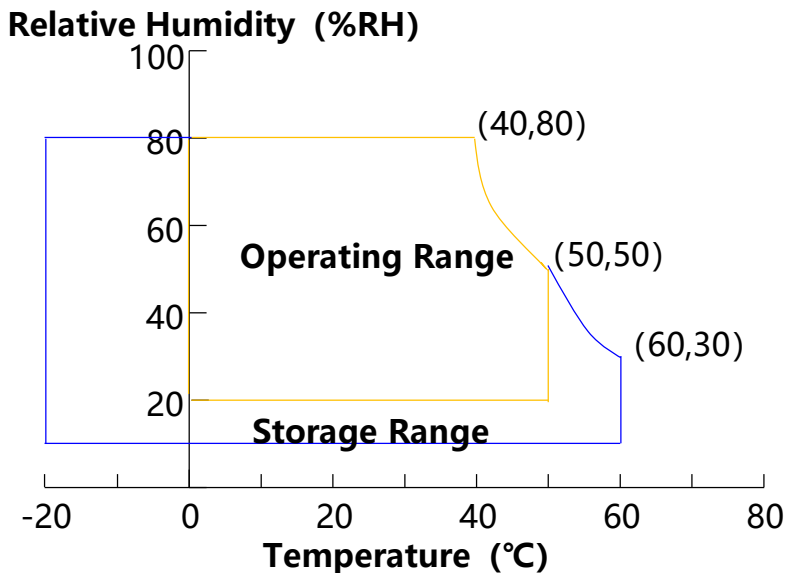

3.0 ELECTRICAL SPECIFICATIONS

3.1 TFT LCD Module

< Table 3. Open cell Electrical specifications > [Ta =25±2 °C]

Parameter	Symbol	Values			Unit	Notes	
		Min.	Typ.	Max.			
Power Supply Voltage	VDD	3.0	3.3	3.6	V	Note 1	
Power Supply Ripple Voltage	VRP	-	-	300	mV		
Power Supply Current	IDD	-	300	700	mA		
Rush current	IRUSH	-	-	2	A	Note 2	
eDP Interface	Main link swing voltage	$ V_{ID} $	100	-	1000	mV	
	Common mode voltage	Vcm	0	-	2	V	
Power Consumption	P _D		1.08	2.1	W	Note 1	

Notes : 1. The supply voltage is measured and specified at the interface connector of FOB.

The current draw and power consumption specified is for 3.3V at 25 °C

Max value at H 1 Line Pattern

a) Typ : Mosaic Pattern

b) Max : H1L Pattern

2. The duration of rush current is about 2ms and rising time of Power Input

is 1ms(min)

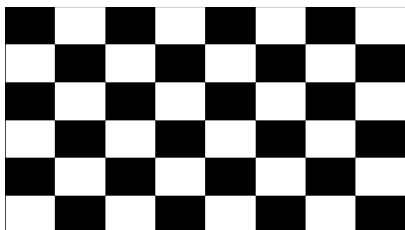

(a)

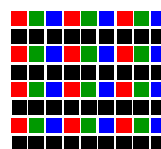

(b)

3.2 Back-Light Unit

< Table 4. LED Driving guideline specifications >

[Ta =25±2 °C]

Parameter		Symbol	Values			Unit	Notes
			Min.	Typ.	Max.		
PWM Control Level	PWM High Level	-	2.7	3.3	5	V	
	PWM Low Level	-	0	-	0.7	V	
LEDEN Control Level	LEDEN High Level	-	2.7	3.3	5	V	
	LEDEN Low Level	-	0	-	0.7	V	
PWM Control Frequency		F_{PWM}	200	-	10000	Hz	
Duty Ratio		-	1	-	100	%	

4.0 INTERFACE CONNECTION

4.1 Interface Input Signal & Power

- eDP Connector : MSAK24025P30 or Equivalent

< Table5. Pin Assignment for **open cell** Connector >

PIN #	Symbol	Description Remark	PIN #	Symbol	Description Remark
1	NC	NC	16	H_GND	Ground
2	H_GND	Ground	17	HPD	Hot Plug Detect Output
3	LANE1_N	eDP RX Channel 1 Negative	18	BL_GND	LED Ground
4	LANE1_P	eDP RX Channel 1 Positive	19	BL_GND	LED Ground
5	H_GND	Ground	20	BL_GND	LED Ground
6	LANE0_N	eDP RX Channel 0 Negative	21	BL_GND	LED Ground
7	LANE0_P	eDP RX Channel 0 Positive	22	BL_ENABL E	LED Enable Pin(+3.3V Input)
8	H_GND	Ground	23	BL_PWM	System PWM Signal Input
9	AUX_CH_P	eDP AUX CH Positive	24	NC	No Connection
10	AUX_CH_N	eDP AUX CH Negative	25	NC	No Connection
11	H_GND	Ground	26	BL_POWER	LED Power Supply 10.8V-13.2V
12	LCD_VCC	Power Supply, 3.3V (typ.)	27	BL_POWER	LED Power Supply 10.8V-13.2V
13	LCD_VCC	Power Supply, 3.3V (typ.)	28	BL_POWER	LED Power Supply 10.8V-13.2V
14	BIST	Panel Self Test Enable	29	BL_POWER	LED Power Supply 10.8V-13.2V
15	H_GND	Ground	30	NC	No Connection

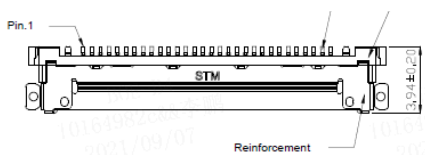

4.2 Dimension

CNT Dimension

-30pin Connector: MSAK24025P30

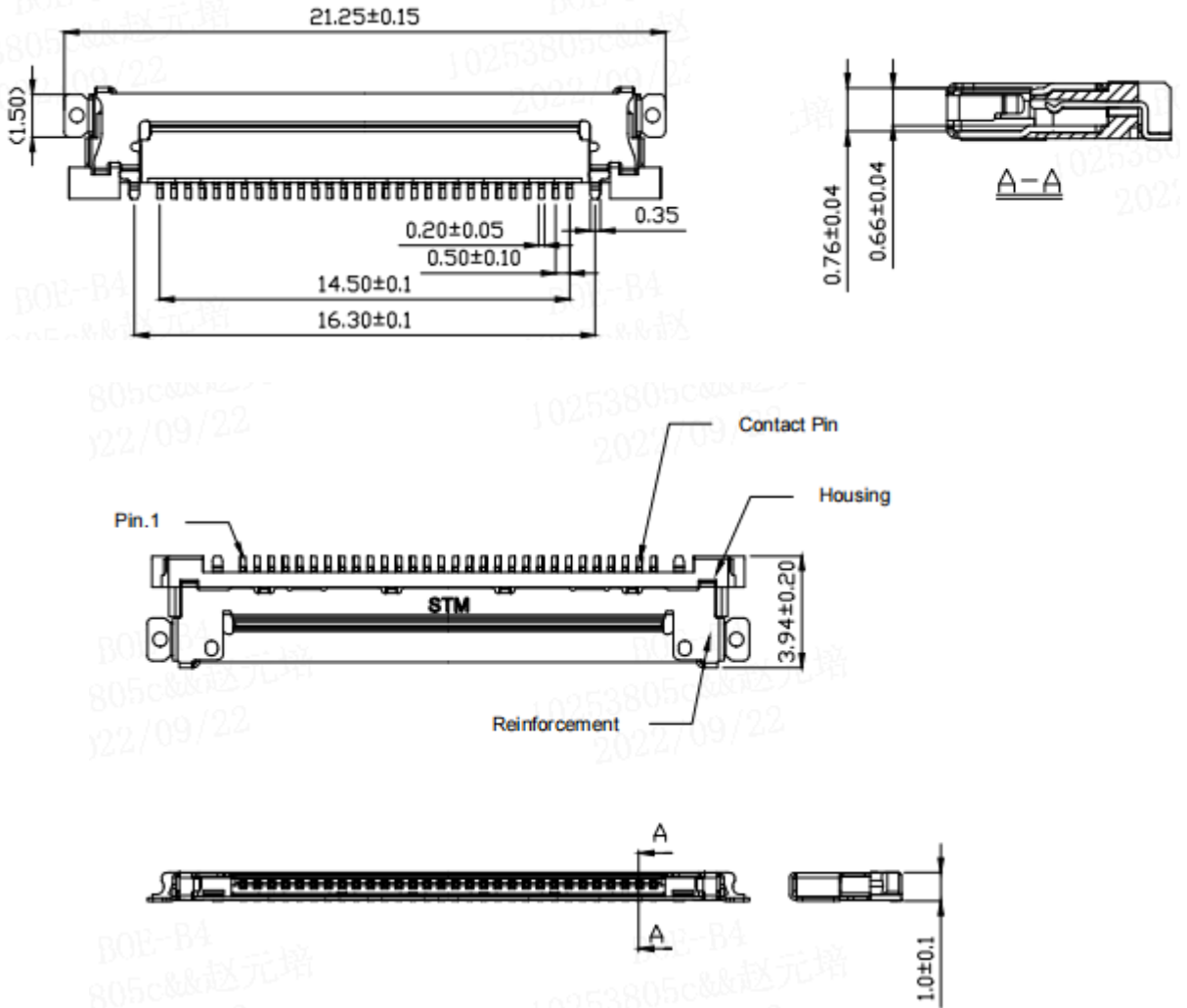

4.3 Pin assignment for PWM驱动

Connector : PF040-B09B-C09 or Equivalent.

< Table6. Pin assignment for LED driver >

PIN #	Symbol	Description Remark
1	LED1	LED-
2	LED2	
3	LED3	
4	LED4	
5	NC	NC
6	NC	
7	VLEDOUT	LED+
8	VLEDOUT	
9	VLEDOUT	

5.0 SIGNAL TIMING SPECIFICATION

5.1 Timing Parameters

< Table 8. Timing Table >

Parameter	Symbol	Value			Unit
		Min.	Typ.	Max.	
DCLK Frequency	fclk	138.5	148.5	153.2	MHz
Horizontal display area	thd	1920			pixel
HSYNC period time	th	2080	2200	2240	pixel
HSYNC blanking	thb+ thfp	160	280	320	pixel
Vertical display area	Tvd	1080			H
Frequency	fV	57	60	-	Hz
VSYNC period time	Tv	1110	1125	1140	H
VSYNC blanking	Tvb+ Tvfp	30	45	60	H

- Note
1. Best operation clock frequency is 148.5Mhz.
 2. Frequency] = [H Total] * [V Total] * [vertical Frame rate]
H Total, V Total and Frame rate]should operate within the range between Frequency_Min and Frequency_Max
 3. Except Best operation clock frequency, FOS(Flicker & Brightness & Crosstalk, Etc.) are not guaranteed.
 4. Main frequency Max is 60Hz

5.4 Power Sequence

To prevent a latch-up or DC operation of the Open Cell, the power on/off sequence shall be as shown in below

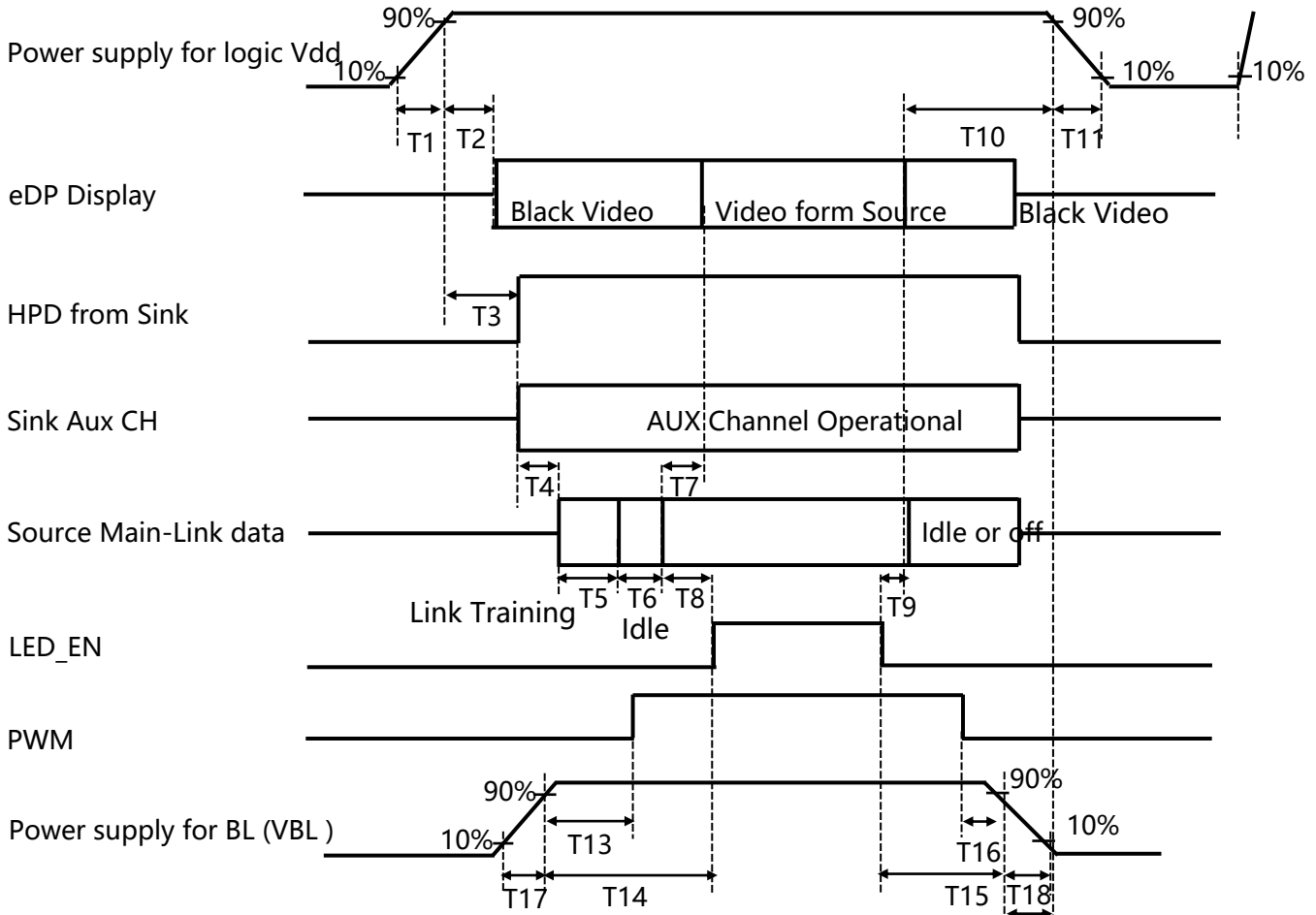

- $0.5\text{ms} \leq T1 \leq 10\text{ms}$
- $0\text{ms} \leq T2 \leq 200\text{ms}$
- $0\text{ms} \leq T3 \leq 200\text{ms}$
- $0\text{ms} \leq T13$
- $0\text{ms} \leq T14$
- $0\text{ms} \leq T17$
- $80\text{ms} \leq T8$
- $0\text{ms} \leq T7 \leq 50\text{ms}$
- $0\text{ms} \leq T10 \leq 500\text{ms}$
- $0.5\text{ms} \leq T11 \leq 10\text{ms}$
- $5\text{ms} \leq T12$
- $0\text{ms} \leq T15$
- $0\text{ms} \leq T16$
- $0\text{ms} \leq T18$

Notes:

1. When the power supply VDD is 0V, keep the level of input signals on the low or keep high impedance.
2. Do not keep the interface signal high impedance when power is on. Back Light must be turn on after power for logic and interface signal are valid.

6.0 OPTICAL SPECIFICATIONS Luminance of White

6.1 Overview

The test of optical specifications shall be measured in a dark room (ambient luminance ≤ 1 lux and temperature = $25 \pm 2^\circ\text{C}$) with the equipment of Luminance meter system (OTS-PR730 & PR810) and test unit shall be located at an approximate distance 50cm from the LCD surface at a viewing angle of θ and Φ equal to 0° . We refer to $\theta\phi=0$ ($=\theta 3$) as the 3 o' clock direction (the "right"), $\theta\phi=90$ ($=\theta 12$) as the 12 O' clock direction ("upward"), $\theta\phi=180$ ($=\theta 9$) as the 9 O' clock direction ("left") and $\theta\phi=270$ ($=\theta 6$) as the 6 O' clock direction ("bottom"). While scanning θ and/or ϕ , the center of the measuring spot on the Display surface shall stay fixed.

6.2 Optical Specifications

< Table15. Optical Table >

Item	Symbol	Condition	Min	Typ.	Max	Unit	Note
Luminance of White	Y_w		300	350	-	cd/m ²	
Viewing Angle	θ_L	$Cr \geq 10$	80	85	--	deg	Note 1
	θ_R		80	85	--		
	ψ_T		80	85	--		
	ψ_B		80	85	--		
Contrast Ratio	Cr	$\theta=0^\circ$	600	800		-	Note 2
Response Time	Tr+Tf	FF=0°	-	30	35	ms	Note 3
Color Coordinate of CIE1931	Rx	$\theta=0^\circ$	-0.03	0.668	+0.03	-	Note 4
	Ry			0.326			
	Gx			0.276			
	Gy			0.591			
	Bx			0.138			
	By			0.095			
	Wx			0.295			
	Wy			0.325			
NTSC Ratio	NTSC	CIE1931	66	72	--	%	Note 5
Polarization Direction of Front Polarizer	PdF			0°		deg	Note 6
Polarization Direction of Rear Polarizer	PdR			90°		Deg	
Gamma Scale			2.0	2.2	2.4		

Note 1: The definition of Viewing Angle

Refer to the graph below marked by θ and ϕ .

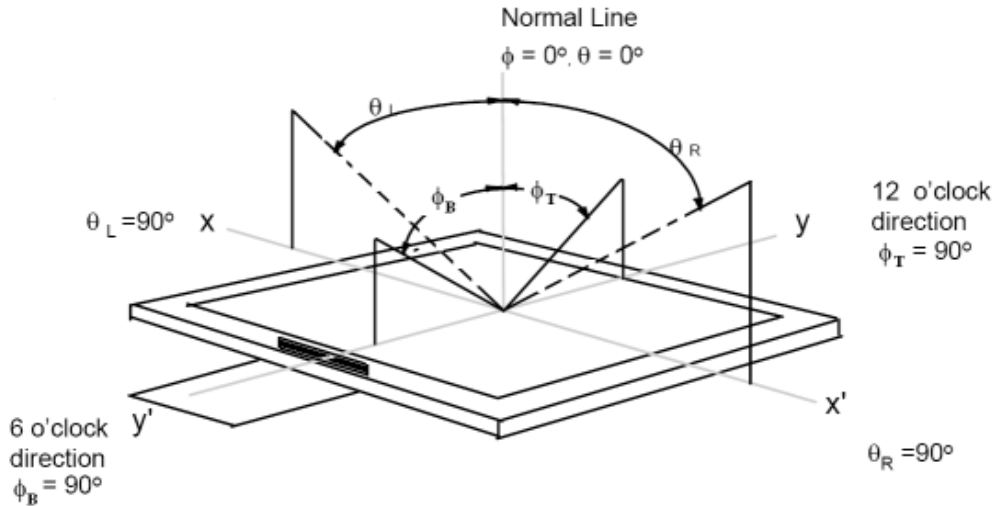

Note 2: The definition of Contrast Ratio (Test LCM using CS2000 or similar equipments):

$$\text{Contrast Ratio (CR)} = \frac{\text{Luminance When LCD is at "White" state}}{\text{Luminance When LCD is at "Black" state}}$$

(Contrast Ratio is measured in optimum common electrode voltage)

Note 3: Definition of Response time. (Test LCD using DMS501 or similar equipments):

The output sign also photo detector are measured when the input sign also are changed from "black" to "white" (Voltage falling time) and from "white" to "black" (Voltage rising time), respectively. The response time is defined as the time interval between the 10% and 90% of amplitudes. Refer to figures below.

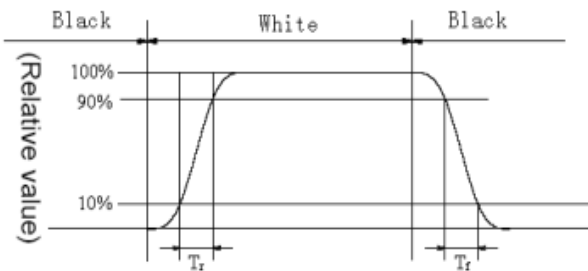

Measured Response Time	Target																	
	0	18	31	47	63	78	90	111	127	143	159	178	191	207	223	239	255	
0																		
18																		
31																		
47																		
63																		
78																		
90																		
111																		
127																		
143																		
159																		
178																		
191																		
207																		
223																		
239																		
255																		

Response time of gray to gray:

Response time T_g is the average time required for display transition by switching the input signal as below table and is based on Frame rate $f_v = 60\text{Hz}$ to optimize. Each time in below table is defined as Figure 2 and shall be measured by switching the signals for "any level of gray (bright)" and any level of gray (dark)

5. The output signals of photo detector are measured when the input signals are changed from "Lx" to "Ly", $x, y = [0, 7]$. The response time is defined as the time interval between the 10% and 90% of amplitudes. The result of the test can be noted as below:

Note 4: Color Coordinates of CIE 1931

The test condition is at ILED=120mA and measured on the surface of LCD module at 25°C.

Measurement equipment: CS2000 or similar equipments

The Color Coordinate (CIE 1931) is the measurement of the center of the display shown in below figure.

Note 5: Definition of Color of CIE Coordinate and NTSC Ratio.

$$S = \frac{\text{area of RGB triangle}}{\text{area of NTSC triangle}} \times 100\%$$

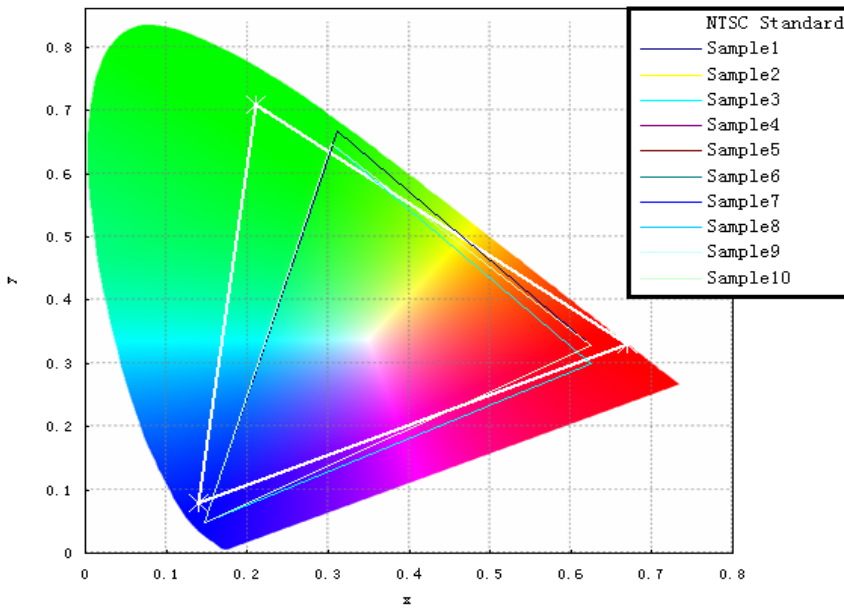

Note 6: Polarization Direction Definition

- Viewing direction is normal user viewing direction which is vertical to the display surface
- The polarizer which is closer to viewer is defined as Front Polarizer
- The polarizer which is on the rear side of viewer is defined as Rear Polarizer
- The X axis is defined as parallel line to top & bottom sidelines of the Active Area
- PdF which is marked in blue arrow is polarization degree of Front polarizer
- PdR which is marked in red arrow is polarization degree of Back polarizer
- The polarization degree parameter must be indicated in range of 0deg to 180deg according to above definition

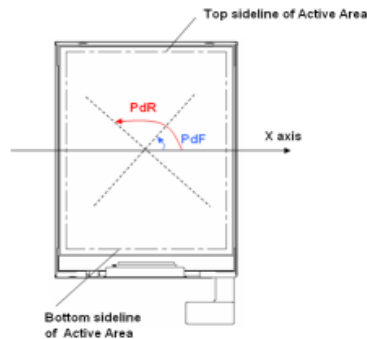

Note 7: Definition of gray inversion angle

- Refer to the graph of note 9.
- Using luminance test method.
- Test pattern : 128 gray
- If the viewing direction is 12 o' clock ,then test the luminance while $\theta = -60^\circ, \theta = -50^\circ, \theta = -40^\circ, \theta = -30^\circ, \theta = -20^\circ, \theta = -10^\circ, \theta = 0^\circ, \theta = 10^\circ, \theta = 20^\circ, \theta = 30^\circ, \theta = 40^\circ, \theta = -50^\circ, \theta = 60^\circ$. The luminance test as figure below:

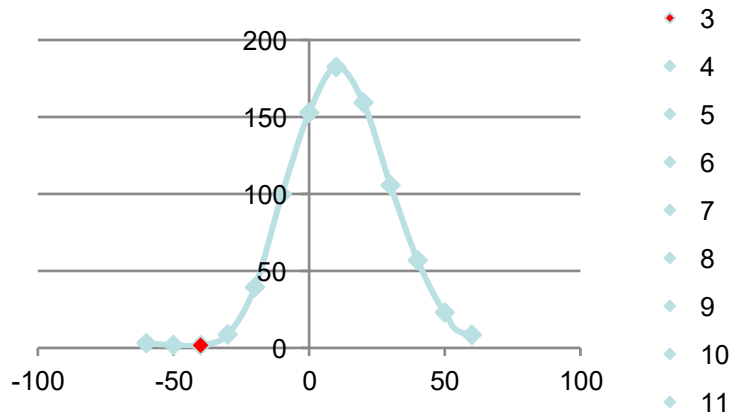

7.0 MECHANICAL CHARACTERISTICS

7.1 Dimensional Requirements

As shown in Table 13.

< Table 13. Dimensional Parameters >

Parameter	Specification	Unit
Dimensional outline	350.72*204.98*2.82	mm
Weight	TBD	gram
Active area	344.16(H)*193.59(V)	mm
Pixel pitch	0.17925 (H) X 0.17925 (V)	um
Number of pixels	1920 (H) ×1080 (V)	pixels

7.2 Anti-Glare and Polarizer Hardness.

The surface of the LCD has an anti-glare coating to minimize reflection and a coating to reduce scratching.

8.0 RELIABILITY TEST

The Reliability test items and its conditions are shown in below.

<Table 12. Reliability Test Parameters >

No	Test Items	Conditions	Remark
1	High temperature storage test	Ta = 60°C , 60%RH, 240 hrs	
2	Low temperature storage test	Ta = -20°C , 240 hrs	
3	High temperature & high humidity operation test	Ta = 50°C , 80%RH, 240 hrs	
4	High temperature operation test	Ta = 50°C , 60%RH, 240 hrs	
5	Low temperature operation test	Ta = 0°C , 240 hrs	
6	Thermal shock	Ta = -20 °C ↔ 60 °C (0.5 hr), 60%±3%RH, 100 cycle	
7	Vibration test (non-operating)	Ta = 25°C , 60%RH, 1.05Grms, 5~200Hz, Random ±Z, 2hr	
9	Electro-static discharge test (operating)	150pF, 330Ω, ±6kV(Contact), ±8kV (Air) Ta = 25°C , 60%RH,	Note 1

Notes :

1. Self- recovery and restart recovery is allowed. No hardware failures.

9.0 PACKING INFORMATION(

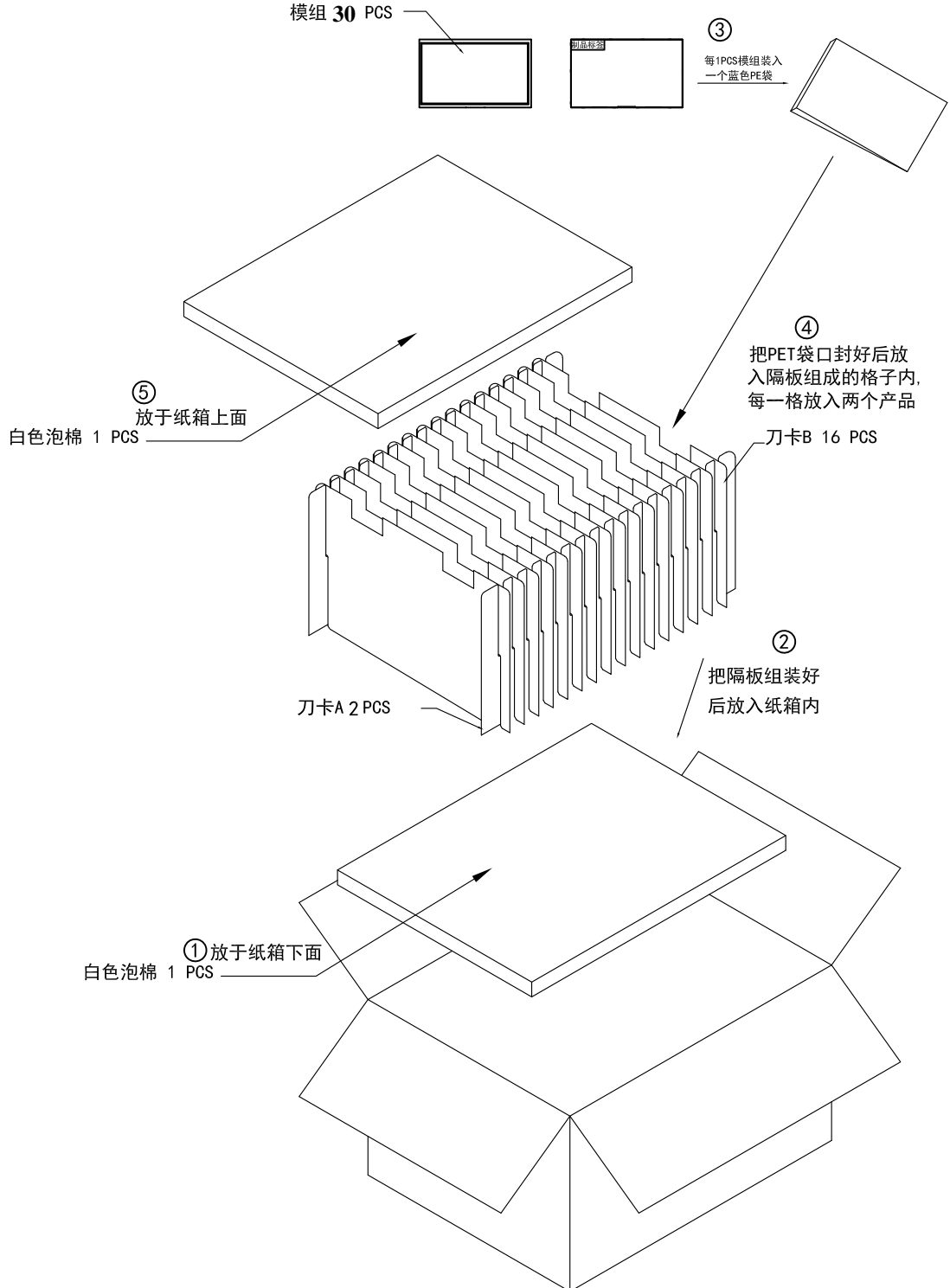

10.0 Handling & Cautions

Please pay attention to the followings when you use this TFT LCD **open cell (OC)** .

10.1 Mounting Precautions

- Use finger-stalls with soft gloves in order to keep display clean during the incoming inspection and assembly process.
- You must mount **an OC** using specified mounting holes (Details refer to the drawings).
- You should consider the mounting structure so that uneven force (ex. Twisted stress, Concentrated stress) is not applied to the **OC**. And the case on which **an OC** is mounted should have sufficient strength so that external force is not transmitted directly to the **OC**.
- Do not apply mechanical stress or static pressure on **OC** ; Abnormal display cause by pressing some parts of **OC** during assembly process , do not belong to product failure, the press should be agreed by two sides.
- Determine the optimum mounting angle, refer to the viewing angle range in the specification for each model.
- Do not apply mechanical stress or static pressure on **OC** , and avoid impact, vibration and falling.
- Acetic acid type and chlorine type materials for the cover case are not desirable because the former generates corrosive gas of attacking the polarizer at high temperature and the latter causes circuit break by electro-chemical reaction.
- Protection film for polarizer on the **OC** should be slowly peeled off before display.
- Be careful to prevent water & chemicals contact the **OC** surface.
- You should adopt radiation structure to satisfy the temperature specification.
- Do not touch, push or rub the exposed polarizers with glass, tweezers or anything harder than HB pencil lead. And please do not rub with dust clothes with chemical treatment.

Do not touch the surface of polarizer for bare hand or greasy cloth.(Some cosmetics are detrimental to the polarizer.)

-
- When the surface becomes dusty, please wipe gently with absorbent cotton or other soft materials like chamois soaks with petroleum benzine. Normal-hexane & alcohol is recommended for cleaning the adhesives used to attach front / rear polarizers. Do not use acetone, toluene , because they cause chemical damage to the polarizer.
 - Wipe off saliva or water drops as soon as possible. Their long time contact with polarizer causes deformations and color fading.
 - **This OC has its circuitry PCBs on the rear side and Driver IC**, should be handled carefully in order not to be stressed.
 - **Avoid impose stress on PCB and Driver IC** during assembly process ,Do not drawing, bending, COF package & wire.
 - Do not disassemble the **OC** .

10.2 Operating Precautions

- Do not connect or disconnect the cable to/from the **OC** at the “Power On” Condition.
- When the **OC** is operating, do not lose CLK, ENAB signals. If any one of these signals is lost, the **OC** would be damaged.
- Obey the supply voltage sequence. If wrong sequence is applied, the **OC** would be damaged.
- Do not allow to adjust the adjustable resistance or switch.
- The electrochemical reaction caused by DC voltage will lead to **LCD open cell** degradation, so DC drive should be avoided.
- The **LCD panel** use C-MOS LSI drivers, so customers are recommended that any unused input terminal would be connected to Vdd or Vss, do not input any signals before power is turn on, and ground you body, work/assembly area, assembly equipment to protect against static electricity.
- Do not exceed the absolute maximum rating value. (supply voltage variation, input voltage variation, variation in part contents and environmental temperature, and so on) Otherwise **the OC** may be damaged.
- **OC** has high frequency circuits. Sufficient suppression to the electromagnetic interference shall be done by system manufacturers. Grounding and shielding methods may be important to minimized the interference.

- The cables should be as short as possible between System Board and PCB interface.
- Connectors are precision devices to transmit electrical signals, and operators should plug in parallel.
- Be careful for condensation at sudden temperature change. Condensation makes damage to polarizer or electrical contacted parts. And after fading condensation, smear or spot will occur.
- For long-term lighting products, it is recommended to shut down periodically.
- If the product is used for a long time under the condition of 7*24 hrs, it is strongly recommended to contact TPS for filed application engineering advice.
- Long time and large angle forward use or unconventional use, It is strongly recommended to contact TPS for filed application engineering advice.
- Products exposed to low temperature environment for a long time, need to carry out necessary protection, low temperature environment is usually refrigerators, vending machine Etc...

10.3 Electrostatic Discharge Precautions

- Avoid the use work clothing made of synthetic fibers. We recommend cotton clothing or other conductivity-treated fibers.
- Since an OC is composed of electronic circuits, it is not strong to electrostatic discharge. Make certain that treatment persons are connected to ground through wrist band etc.
- Do not close to static electricity to avoid product damage.
- Do not touch interface pin directly.

10.4 Precautions for Strong Light Exposure

- Do not leave the open cell operation or storage in Strong light. Strong light exposure causes degradation of polarizer and color filter.

10.5 Precautions for Storage

A. Atmosphere Requirement

ITEM	UNIT	MIN	TYP	MAX
Storage Temperature	(°C)	5	25	40
Storage Humidity	(%rH)	40	50	75
Storage Life	6 months			
Storage Condition	<ul style="list-style-type: none"> The storage room should be equipped with a dark and good ventilation facility. Prevent products from being exposed to the direct sunlight, moisture and water. The product need to keep away from organic solvent and corrosive gas. Be careful for condensation at sudden temperature change. Storage condition is guaranteed under packing conditions. 			

B. Package Requirement

- The product should be placed in a sealed polythene bag.
- Product Should be placed on the pallet, Which is away from the floor, Be cautions not to pile the product up.
- The polarizer surface should not come in contact with any other object. It is recommended that they be stored in the container in which they were shipped.
- As the original protective film, do not use the adhesive protective film to avoid change of Pol color and characteristic.

10.6 Precautions for protection film

- Remove the protective film slowly, keeping the removing direction approximate 30-degree not vertical from panel surface, If possible, under ESD control device like ion blower, and the humidity of working room should be kept over 50%RH to reduce the risk of static charge.
- People who peeled off the protection film should wear anti-static strap and grounded well.

10.7 Appropriate Condition for Commercial Display

-Generally large-sized LCD **panels** are designed for consumer applications . Accordingly, long-term display like in Commercial Display application, can cause uneven display including image sticking. To optimize module's lifetime and function, several operating usages are required.

1. Normal operating condition

- Temperature: $20\pm 15^{\circ}\text{C}$
- Operating Ambient Humidity : $55\pm 20\%$
- Display pattern: dynamic pattern (Real display)
- Well-ventilated place is recommended to set up Commercial Display system

2. Special operating condition

a. Ambient condition

- Well-ventilated place is recommended to set up Commercial Display system.

b. Power and screen save

- Periodical power-off or screen save is needed after long-term display.

c. As the low temperature, the response time is greatly delayed. As the high temperatures (higher than the operating temperature) the LCD **panel** may turn black screen. The above phenomenon cannot explain the failure of the display. When the temperature returns to the normal operating temperature, the LCD **panel** will return to normal display.

d. When expose to drastic fluctuation of temperature (hot to cold or cold to hot) ,the LCD **panel** may be affected; Specifically, drastic temperature fluctuation from cold to hot ,produces dew on the LCD **panel** 's surface which may affect the operation of the polarizer and LCD **panel** .

e. Do not exceed the absolute maximum rating value. (supply voltage variation, input voltage variation, variation in part contents and environmental temperature, and so on) Otherwise the **OC** may be damaged.

f. Product reliability and functions are only guaranteed when the product is used under right operation usages. If product will be used in extreme conditions such as high temperature, high humidity, high altitude, **highlight**, special display images, running time, long time operation, outdoor operation, etc. It is strongly recommended to contact TPS for filed application engineering advice. Otherwise, its reliability and function may not be guaranteed. Extreme conditions are commonly found at airports, transit stations, banks, stock market and controlling systems.

3. Operating usages to protect against image sticking due to long-term static display.
 - a. Suitable operating time: under 20 hours a day.
 - b. Static information display recommended to use with moving image.
 - Cycling display between 5 minutes' information(static) display and 10 seconds' moving image.
 - c. Background and character (image) color change
 - Use different colors for background and character, respectively.
 - Change colors themselves periodically.
 - d. Avoid combination of background and character with large different luminance.
 - 1) Abnormal condition just means conditions except normal condition.
 - 2) Black image or moving image is strongly recommended as a screen save
4. Lifetime in this spec. is guaranteed only when Commercial Display is used according to operating usages.
5. **OC** should be turned clockwise based on front view when used in portrait mode. (**OC支持横竖兼容时按照实际情况填写,不支持横竖兼容时删除此条**)

10.8 Other Precautions

A. LC Leak

- If the liquid crystal material leaks from the panel, it is recommended to wash the LC with acetone or ethanol and then burn it.
- If the liquid crystal material leaks from the panel, it should be kept away from the eyes or mouth. In case of contact with hands, skin or clothes, it has to be washed away thoroughly with soap.
- If LC in mouth, mouth need to be washed, drink plenty of water to induce vomiting and follow medical advice.
- If LC touch eyes, eyes need to be washed with running water at least 15 minutes.

B. Rework

- When returning the **Open Cell** for repair or etc., Please pack the **OC** not to be broken. We recommend to use the original shipping packages.
- C. In order to prevent potential problems, flicker should be adjusted by optimizing the Vcom value in customer **panel** Line through the I2C Interface. (**Q/Single/OC出货时填写**)

11.0 EDID Table

00	Header	00	0	0	EDID Header
01		FF	255	255	
02		FF	255	255	
03		FF	255	255	
04		FF	255	255	
05		FF	255	255	
06		FF	255	255	
07		00	0	0	
08	ID Manufacturer Name	09	9	BOE	ID = BOE
09		E5	229		
0A	ID Product Code	AB	171	2987	ID = 2987
0B		0B	11		
0C	32-bit serial No.	00	0	0	
0D		00	0	0	
0E		00	0	0	
0F		00	0	0	
10	Week of manufacture	1B	27	27	
11	Year of Manufacture	20	32	2022	Manufactured in 2022
12	EDID Structure Ver.	01	1	1	EDID Ver 1.0
13	EDID revision #	04	4	4	EDID Rev. 0.4
14	Video input definition	95	149	-	Video Signal Interface
15	Max H image size	1E	30	31	31cm (Approx)
16	Max V image size	11	17	17	17cm (Approx)
17	Display Gamma	78	120	2.2	Gamma curve = 2.2
18	Feature support	02	2	-	Feature Support
19	Red/Green low bits	BA	186	-	Red / Green Low Bits
1A	Blue/White low bits	F0	240	-	Blue / White Low Bits
1B	Red x high bits	A7	167	0.655	Red (x) = 10100111 (0.655)
1C	Red y high bits	56	86	0.339	Red (y) = 01010110 (0.339)
1D	Green x high bits	50	80	0.315	Green (x) = 01010000 (0.315)
1E	Green y high bits	9F	159	0.624	Green (y) = 10011111 (0.624)
1F	Blue x high bits	27	39	0.152	Blue (x) = 00100111 (0.152)
20	Blue y high bits	0E	14	0.058	Blue (y) = 00001110 (0.058)
21	White x high bits	50	80	0.313	White (x) = 01010000 (0.313)
22	White y high bits	54	84	0.329	White (y) = 01010100 (0.329)
23	Established timing 1	00	0	-	--
24	Established timing 2	00	0	-	
25	Established timing 3	00	0	-	

11.0 EDID Table

26	Standard timing #1	01	1		Not Used
27		01	1		
28	Standard timing #2	01	1		Not Used
29		01	1		
2A	Standard timing #3	01	1		Not Used
2B		01	1		
2C	Standard timing #4	01	1		Not Used
2D		01	1		
2E	Standard timing #5	01	1		Not Used
2F		01	1		
30	Standard timing #6	01	1		Not Used
31		01	1		
32	Standard timing #7	01	1		Not Used
33		01	1		
34	Standard timing #8	01	1		Not Used
35		01	1		
36	Detailed timing/monitor descriptor #1	C0	192	147.8	147.84MHz Main clock
37		39	57		
38		80	128	1920	Hor Active = 1920
39		18	24	280	Hor Blanking = 280
3A		71	113	-	4 bits of Hor. Active + 4 bits of Hor. Blanking
3B		38	56	1080	Ver Active = 1080
3C		28	40	40	Ver Blanking = 40
3D		40	64	-	4 bits of Ver. Active + 4 bits of Ver. Blanking
3E		30	48	48	Hor Sync Offset = 48
3F		20	32	32	H Sync Pulse Width = 32
40		36	54	3	V sync Offset = 3 line
41		00	0	6	V Sync Pulse width : 6 line
42		35	53	309	Horizontal Image Size = 309 mm (Low 8 bits)
43		AE	174	174	Vertical Image Size = 174 mm (Low 8 bits)
44		10	16	-	4 bits of Hor Image Size + 4 bits of Ver Image Size
45		00	0	0	Hor Border (pixels)
46		00	0	0	Vertical Border (Lines)
47	1A	26	-	Detailed timing Definition	

11.0 EDID Table

48	Detailed timing/monitor descriptor #2	00	0	0.0	-	
49		00	0			
4A		00	0	0	-	
4B		00	0	0	-	
4C		00	0	-	-	
4D		00	0	0	-	
4E		00	0	0	-	
4F		00	0	-	-	
50		00	0	0	-	
51		00	0	0	-	
52		00	0	0	-	
53		00	0	0	-	
54		00	0	0	-	
55		00	0	0	-	
56		00	0	-	-	
57		00	0	0	-	
58		00	0	0	-	
59		00	0	-	-	
5A		Detailed timing/monitor descriptor #3	00	0		Indicates descriptor #3 is a display Descriptor
5B			00	0		
5C	00		0		Reserved	
5D	FE		254		Tag: ASCII String	
5E	00		0		Reserved	
5F	42		66	B	Manufacture name : BOECQ	
60	4F		79	O		
61	45		69	E		
62	20		32			
63	43		67	C		
64	51		81	Q		
65	0A		10			
66	20		32			
67	20		32			
68	20	32				
69	20	32				
6A	20	32				
6B	20	32				

11.0 EDID Table

6C	Detailed timing/monitor descriptor #4	00	0		Indicates descriptor #4 is a display Descriptor
6D		00	0		
6E		00	0		Reserved
6F		FE	254		Tag: ASCII String
70		00	0		Reserved
71		4E	78	Q	Model name : QV156FHM-N83
72		56	86	V	
73		31	49	1	
74		34	52	5	
75		30	48	6	
76		46	70	F	
77		48	72	H	
78		4D	77	B	
79		2D	45	-	
7A		4E	78	N	
7B	36	54	8		
7C	33	51	3		
7D	0A	10			
7E	Extension flag	00	0	1	Extension flag
7F	Checksum	FA	250	-	Checksum

Notes:

1. EDID custom information not required

12.0 Mechanical Drawing

1	2	3	4	5	6	7	8
<p>Date: 2022.10.26 Page: 1/1 THE THIRD ANGLE</p>				Customer Code:		SPECIFICATION OF BACKLIGHT	
<p>Customer: 客户</p>				Customer's S P/N		Edition (版本) 01	
<p>Product Model</p>				TTS156BHT-01		Approval (核准)	
<p>Check item: 1~9</p>				DESIGN (设计)		Check (检查)	
<p>12: Check item: 1~9</p>				REVISE (修改内容)		Design (设计)	

*350/250.3 (OUTLINE)
*346.86±0.3 (UP PDL)
*344.65±0.2 (A-A)

Notes:

- Unit:mm.
- Do not scale drawing.
- All radii without dimension R0.2.
- Modification Mark.
- draft angle: 1°
- Backlight luminance :350cd/m²(TYP)
- Luminance uniformity: 75%(min) (min/max*100%)
- UnSpecified Tolerance is ±0.5
- Operation conditions :If= 120mA, Vf=28~32V
- Color coordinate:X=0.27~0.35, Y=0.28~0.36
- All materials comply with RoHS
- The measured value of luminance and color coordinate bases FX's BM-7
- Check item: 1~9

Backlight LED10串6并60颗 Circuit

REV	DATE	DESCRIPTION(修改内容)	REVISER	APPROVE	DATE

NO.	DESCRIPTION	QUANTITY
12	Front Iron Frame (上铁框)	0
11	Connector+Wire (连接器+导线)	0
10	Double-sided stick (双面胶)	2
9	HOUSING (塑胶框)	0
8	FPC(柔性电路板)	1
7	Wire(导线)	0
6	LED(发光二极管)	60
5	BEF(偏光片)	2
4	Diffuser Film(扩散片)	1
3	Light guide plate (导光板)	1
2	Reflector Film(反射膜)	1
1	Rear Iron Frame (下铁框)	1