



A Professional Manufacturer of Display

Manufacturer Certificated



CERT. No.: 282Q19070712006

CERT. No.: 282E19070712007

Product Specification

Model: TBZ050HD-01C

TFT Display with Driver Board

This module uses ROHS material



Tailor Pixels Technology Co., Ltd.

www.tailorpixels.com

tailor@tailorpixels.com

Ph: 86-755-8821 2653

Contents in this document are subject to change without notice. No part of this document can be reproduced or transmitted by any means for any purpose without the written permission of Tailor Pixels Technology Co., Ltd.

Contents

1. Record of Revision	2
2. General Specifications	3
3. Electrical Characteristics	3
4. PIN-MAP	4
5. Block Diagram	5
6. Mechanical Drawing	6
7. Optical Characteristics	8
8.Environmental / Reliability Tests	11
9.Precautions For Use of LCD modules	12

2. General Specifications

Feature		Spec
Characteristics	Size(inch)	5.0
	LCM Resolution supported(Max)	800*480
	Pixel Configuration	R.G.B.-Stripe
	Interface	HDMI/VGA
	Touch Panel Optional	Yes
	Key Optional	Yes
	Viewing Direction	ALL
	Brightness (Typ)	400 cd/m2
Mechanical	LCM (W x H xT)	120.70*97.00*6.5mm
	Active Area(W×H)	108.0x64.8mm
	Power connector	Micro-USB
	Audio headset	SMT-3.5mm
	Key connector	8pin/2.0mm
	HDMI connector	HDMI-019S
	VGA connector	12pin/2.0mm

3. Electrical Characteristics

Item	Symbol	MIN	Typ	MAX	Unit
Supply Voltage	VDD	4.8	5.0	5,2	V
Operating Temperature	TOPR	-20	-	70	°C
Storage Temperature	TSTG	-30	-	80	°C

4. PIN-MAP

4.1 HDMI Interface

Pin	Signal	Description
1	TMDS Data 2+	TMDS Transition differential signal 2+
2	TMDS Data2 Sh	Data2 Shielding ground
3	TMDS Data 2-	TMDS Transition differential signal 2-
4	TMDS Data 1+	TMDS Transition differential signal 1+
5	TMDS Data1 Sh	Data1 Shielding ground
6	TMDS Data 1-	TMDS Transition differential signal 1-
7	TMDS Data 0+	TMDS Transition differential signal 0+
8	TMDS Data 0 S	Data0 Shielding ground
9	TMDS Data 0-	TMDS Transition differential signal 0-
10	TMDS Clock+	TMDS Transition differential signal Clock+
11	TMDS Clock Sh	Clock Shielding ground
12	TMDS Clock-	TMDS Transition differential signal Clock-
13	CEC	Electronic protocol CEC
14	NC	NC
15	SCL	I2C Clock Line
16	SDA	I2C DATA Line
17	DDC/CEC GND	Data display channel
18	+5V	+5V Power
19	Hot Plug Detec	Hot Plug Detec

4.2 (Key connector) 8PIN/2.0mm

Pin No.	Symbol	Function
1	+5V	Power supply 5.0V
2	GND	GND
3	LED	Light
4	POWER	ON/OFF
5	MENU	MENU
6	SOURCE	Signal channel switch menu
7	+	Increase key
8	-	Reduce key

4.3 Micro-USB (Power supply)

Pin No.	Symbol	Function
1	+5V	Power supply
2	D-	Data
3	D+	Data
4	GND	Ground

4.4 (VGA)12PIN/2.0mm

Pin No.	Symbol	Function
1	GND	Power ground
2	VS	VSYNC signal
3	HS	HSYNC signal
4	GND	Power ground
5	R+	Red signal +
6	GND	Power ground
7	G+	Green signal +
8	GND	Power ground
9	B+	Blue signal +
10	GND	Power ground
11	SDA	I2C data input
12	SCL	I2C clock

5. Block Diagram

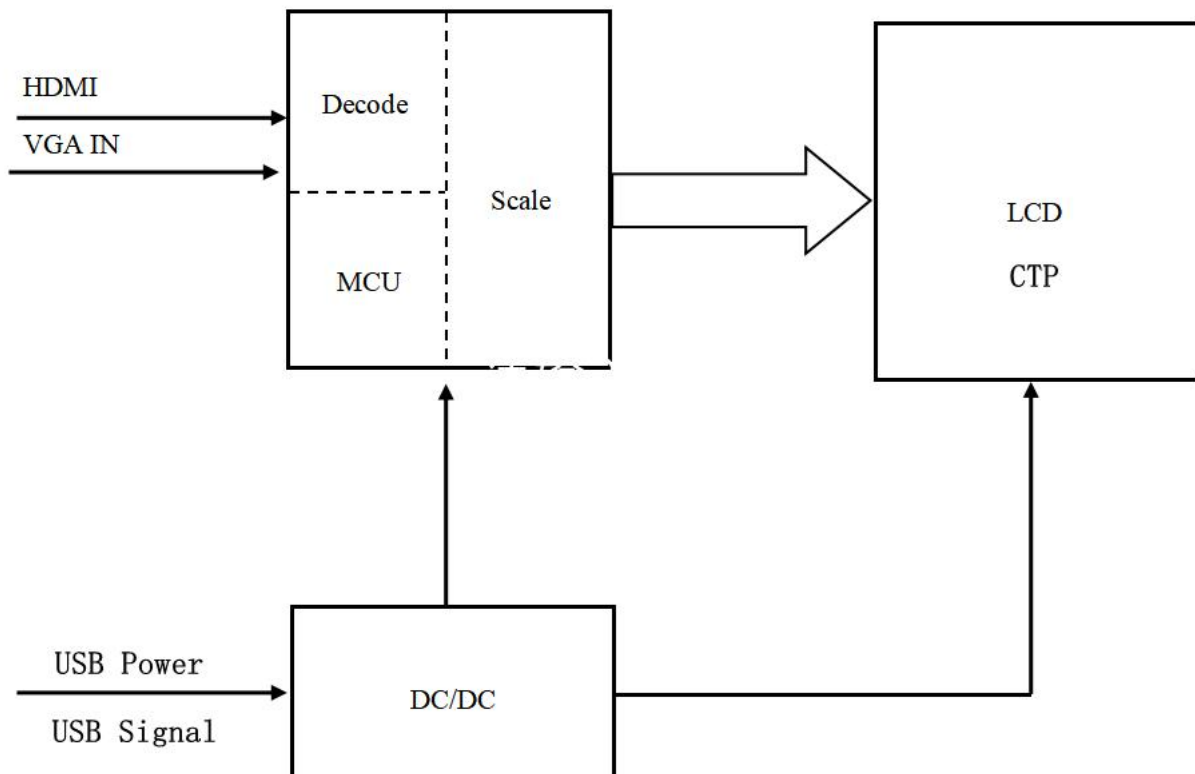

6. Mechanical Drawing

General Specifications:

DISPLAY TYPE:	5.0" TFT
	NORMALLY Black
	TRANSMISSIVE
RESOLUTION:	800 (RGB)*480
Viewing Angle (U/D/L/R)	80/80/80/80
LCM BRIGHTNESS:	400CD/M ² TYP. 350CD/M ² MIN
Chromaticity:	(x=0.27±0.05, y=0.31±0.05)
Homogeneity:	80% typ
Interface:	HDMI/VGA
OPERATING TEMP:	-20° C ~ 70° C
STORAGE TEMP:	-30° C ~ 80° C
Power supply:	Micro-USB
CTP signal:	USB

CTP Specifications:

1	CTP Stackup	Glass-Glass
2	Driver IC	G1911
3	CG surface	>6H
4	Touch function	multitouch
5	OPERATING TEMP:	-20° ~ 70° C
6	STORAGE TEMP:	-30° ~ 80° C
7	Laminating type:	Optical bonding

RoHS

HDMI :

1	TMDS Data 2+
2	TMDS Data2 Shield
3	TMDS Data 2-
4	TMDS Data 1+
5	TMDS Data1 Shield
6	TMDS Data 1-
7	TMDS Data 0+
8	TMDS Data 0 Shield
9	TMDS Data 0-
10	TMDS Clock+
11	TMDS Clock Shield
12	TMDS Clock-
13	CEC
14	NC
15	SCL
16	SDA
17	DDC/CEC GND
18	+5V
19	Hot Plug Detect

Micro USB:

1	+5V
2	D-
3	D+
4	GND

DRAWING NO.		TBZ050HD-01C	
UNIT	mm	SCALE	1:1
3rd Angle		SHEET 1 OF 1	
Tailorpixels A Professional Manufacturer of Display			
TITLE		MODULE SPEC.	
DRAWN	ME. CHECKED		
	EE. CHECKED		
	APPROVED		
VER.	AMENDMENT	DATE	
02		2022.06.25	
01	WANG	DESIGN	
	First Issue		

7.Optical Characteristics

Items	Symbol	Condition	Min.	Typ.	Max.	Unit	Remark
Viewing angles	θ_T	Center CR \geq 10	70	80	-	Degree.	Note2
	θ_B		70	80	-		
	θ_L		70	80	-		
	θ_R		70	80	-		
Contrast Ratio	CR	$\Theta = 0$	800	1000		-	Note1, Note3
Response Time	T_{ON}	25°C	-	30	40	ms	Note1, Note4
	T_{OFF}						
Chromaticity	White	Backlight is on	Typ -0.05	0.270	Typ +0.05	-	Note1, Note5
				0.310		-	
	Red			0.629		-	
				0.326		-	
	Green			0.337		-	
				0.546		-	
	Blue			0.136		-	
				0.143		-	
Uniformity	U		75	80	-	%	Note1, Note6
NTSC			45	50		%	Note5
Luminance	L		350	400			Note1, Note7

Test Conditions:

1. IF= 20mA (one channel), the ambient temperature is 25°C.
2. The test systems refer to Note 1 and Note 2.

Note 1: Definition of optical measurement system.

The optical characteristics should be measured in the darkroom. After 5 minutes of operation, the optical properties are measured at the center point of the LCD screen. All input terminals LCD panel must be ground when measuring the center area of the panel.

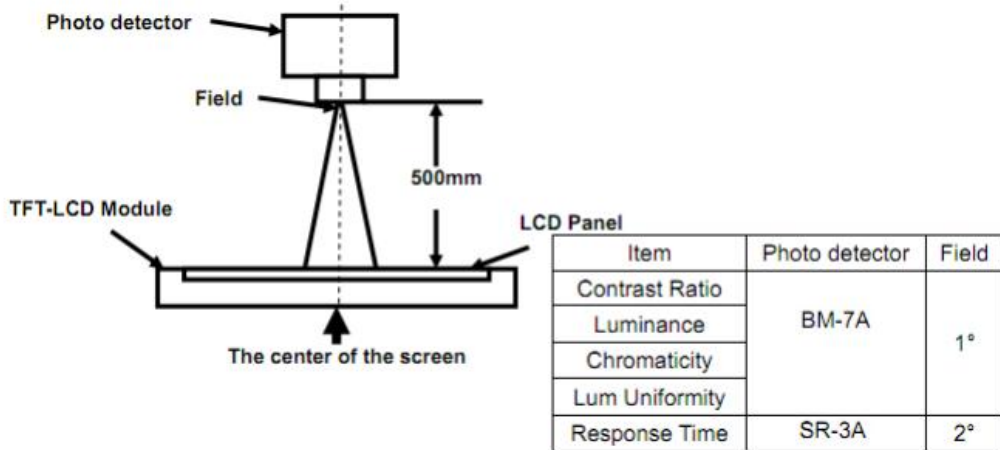

Note 2: Definition of viewing angle range and measurement system.

Viewing angle is measured at the center point of the LCD by CONOSCOPE (ergo-80).

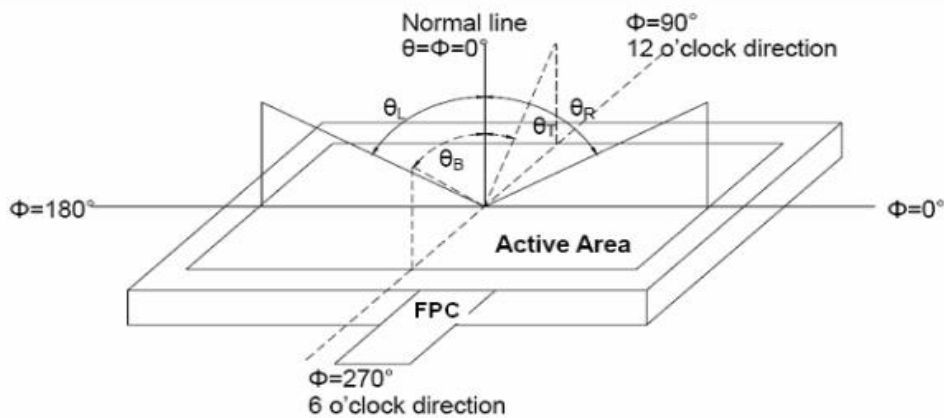

Fig. 1 Definition of viewing angle

Note 3: Definition of contrast ratio

$$\text{Contrast ratio (CR)} = \frac{\text{Luminance measured when LCD is on the "White" state}}{\text{Luminance measured when LCD is on the "Black" state}}$$

Note 4: Definition of Response time (Test LCD using DMS501):

The output signals of photo detector are measured when the input signals are changed from “black” to “white”(rising time) and from “white” to “black”(falling time), respectively. The response time is defined as the time interval between the 10% and 90% of amplitudes. Refer to figure as below.

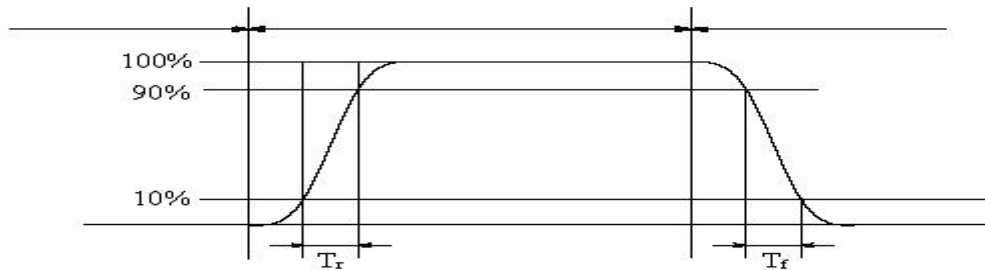

Note 5: Definition of color chromaticity (CIE1931)
Color coordinates measured at center point of LCD.

Note 6: Definition of Luminance Uniformity

Active area is divided into 9 measuring areas (Refer Fig. 2). Every measuring point is placed at the Center of each measuring area

Luminance Uniformity (U) = $L_{min} / L_{max} \times 100\%$

L-----Active area length W----- Active area width

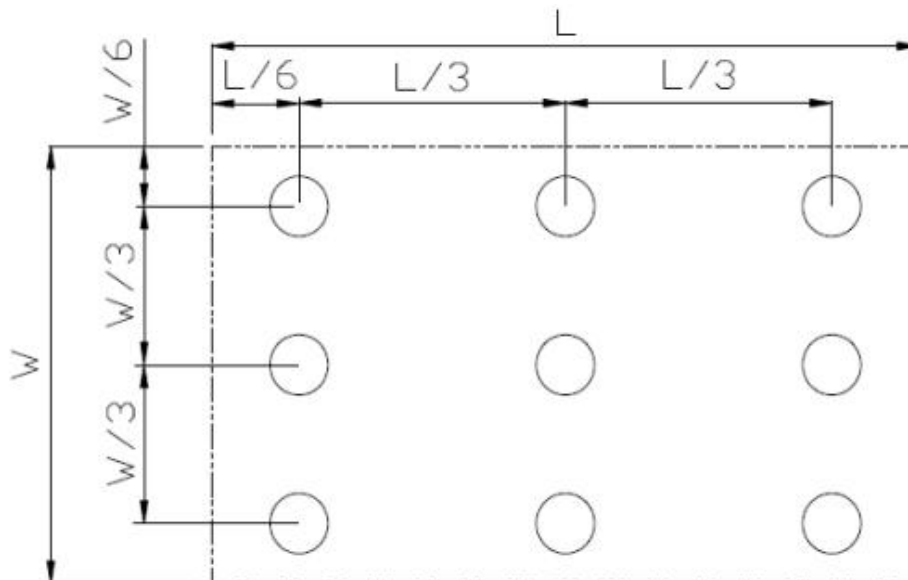

Fig. 2 Definition of uniformity

Lmax: The measured maximum luminance of all measurement position.

Lmin: The measured minimum luminance of all measurement position.

Note 7: Definition of Luminance:

Measure the luminance of white state at center point.

8.Environmental / Reliability Tests

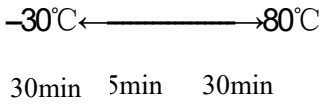
No	Test Item	Test condition	Criterion
1	High Temperature Storage	80°C±2°C 96H Restore 2H at 25°C Power off	1. After testing, cosmetic and electrical defects should not happen. 2. Total current consumption should not be more than twice of initial value.
2	Low Temperature Storage	-30°C±2°C 96H Restore 2H at 25°C Power off	
3	High Temperature Operation	70°C±2°C 96H Restore 2H at 25°C Power on	
4	Low Temperature Operation	-20°C±2°C 96H Restore 4H at 25°C Power on	
5	High Temperature/Humidity Operation	60°C±2°C 90%RH 96H Power on	
6	Temperature Cycle	 after 5 cycle, Restore 2H at 25°C Power off	
7	Vibration Test	10Hz~150Hz, 100m/s ² , 120min	Not allowed cosmetic and electrical defects.
8	Shock Test	Half- sine wave,300m/s ² ,11ms	
9	ESD Test	Air discharge:+/-8KV, Contact discharge:+/-4KV	

Note: 1. T_s is the temperature of panel's surface.
2. T_a is the ambient temperature of sample.

9. Precautions for Use of LCD Modules

9.1 Handling Precautions

9.1.1 The display panel is made of glass. Do not subject it to a mechanical shock by dropping it from a high place, etc.

9.1.2 If the display panel is damaged and the liquid crystal substance inside it leaks out, be sure not to get any in your mouth, if the substance comes into contact with your skin or clothes, promptly wash it off using soap and water.

9.1.3 Do not apply excessive force to the display surface or the adjoining areas since this may cause the color tone to vary.

9.1.4 The polarizer covering the display surface of the LCD module is soft and easily scratched. Handle this polarizer carefully.

9.1.5 If the display surface is contaminated, breathe on the surface and gently wipe it with a soft dry cloth. If still not completely clear, moisten cloth with one of the following solvents:

- Isopropyl alcohol
- Ethyl alcohol

Solvents other than those mentioned above may damage the polarizer. Especially, do not use the following:

- Water
- Ketone
- Aromatic solvents

9.1.6 Do not attempt to disassemble the LCD Module.

9.1.7 If the logic circuit power is off, do not apply the input signals.

9.1.8 To prevent destruction of the elements by static electricity, be careful to maintain an optimum work environment.

- a. Be sure to ground the body when handling the LCD Modules.
- b. Tools required for assembly, such as soldering irons, must be properly ground.
- c. To reduce the amount of static electricity generated, do not conduct assembly and other work under dry conditions.
- d. The LCD Module is coated with a film to protect the display surface. Be care when

peeling off this protective film since static electricity may be generated.

9.2 Storage precautions

9.2.1 When storing the LCD modules, avoid exposure to direct sunlight or to the light of fluorescent lamps.

9.2.2 The LCD modules should be stored under the storage temperature range. If the LCD modules will be stored for a long time, the recommend condition is:

Temperature : 0°C ~ 40°C

Relatively humidity: ≤80%

9.2.3 The LCD modules should be stored in the room without acid, alkali and harmful gas.

9.3 The LCD modules should be no falling and violent shocking during transportation, and also should avoid excessive press, water, damp and sunshine.